

NSW Pool Lifesaving Competition Manual

Last Update: April 2026

INTRODUCTION

The 2026 NSW Pool Lifesaving State Championships will be hosted jointly by Royal Life Saving NSW (RLNSW) and Surf Life Saving NSW (SLSNSW). These Championships will be run in accordance with three existing Rulebooks:

- (i) ILS Competition Rule Book 2025 Edition (Issued August 2025, Effective September 1 2025) accessible [here](#)
- (ii) The RLNSW Club & Competition Handbook (RLNSW Handbook) – Section 3: General Competition Requirements; and Section 4: Pool Lifesaving Competition. Accessible [here](#)

This document summarises the sections that apply at these Championships.

- (iii) Surf Life Saving Surf Sports Manual (SSM) 38th Edition, accessible [here](#)

The ILS Rulebook will be the primary rulebook and unless otherwise stated within this Manual.

This document MUST be read in conjunction with the current National RLSSA Competition Handbook; particularly Section 4 & Section 8, accessible [here](#)

Australia currently has a set of general rules and run modified events which are not outlined in the ILS rulebook. To compensate for these events, each of these rules will be as stated from the RLNSW Handbook or SSM. There are also rules specific to NSW only, which will be highlighted within this document.

The eligibility conditions for age categories, substitution, and other required provisions are provided in the Championship Information and Entry Circular distributed to clubs.

Pools and equipment used in NSW Lifesaving Competitions shall comply with the detailed technical specifications and physical features set out in the current ILS Competition Rulebook - Section 8 Facility and Equipment Standards and Scrutineering Procedures.

1. Table of Contents

1. GENERAL RULES AND PROCEDURES	5
1.1 CONDUCT OF EVENTS	5
1.2 COMPETITION ORGANISATION AND PROCEDURES	5
1.3 WITHDRAWAL AND SUBSTITUTION	6
1.4 SAFETY	6
1.5 COMPETITION CONDITIONS	6
1.6 GENERAL COMPETITION RULES	7
1.7 START AND FINISH PROCEDURES	7
1.7.1 Official Start and Completion of Competition	7
1.7.2 Starts	8
1.7.3 Start Procedure	8
1.7.4 Dive Start Procedure	8
1.7.5 In Water Start Procedure	8
1.7.6 Manikin Relay Start	8
1.7.7 Line Throw Start	9
1.7.8 Start Disqualifications	9
1.7.9 Start Modifications - Equipment	9
1.7.10 Turns	9
1.7.11 Finish	9
1.8 COMPETITION ELIGIBILITY	10
1.8.1 Competition Qualification	10
1.8.2 Determining Age Groups	10
1.8.3 Participation in Individual and Team Events	11
1.9 CODE OF CONDUCT	11
1.9.1 Code of conduct for competitors, technical officials and members	11
1.9.2 Fair-play code for lifesaving competitions	11
1.9.3 Misconduct	12
2. POOL LIFESAVING SPEED EVENTS	14
2.1 GENERAL	14
2.2 SPEED EVENTS AND THEIR PURPOSE	14
2.3 SPECIAL CONDITIONS FOR NSW COMPETITIONS	14
2.3.1 Swim Fins Specifications for U13 and Under Age Category Events	14
2.3.2 Swim Fins Specifications for U14 and Over Age Category Events	14
2.3.3 Rubber Bricks Specifications	15
2.4 SPECIFIC NSW EVENT RULES	15
2.4.1 50m Freestyle Swim with Fins	15
2.4.2 50m Brick Carry	16

2.4.3	4 x 25m Brick Relay	16
2.4.4	100m Brick Carry with Fins.....	17
2.4.5	100m Manikin Carry with Fins (empty manikin)	17
2.4.6	50m Manikin Tow with Fins	18
2.4.7	50m Tube Clip and Swim with Fins	19
2.4.8	4 x 50m Modified Medley Relay	20
3.	MANIKINS	21
3.1	COMPETITORS SURFACING THE MANIKIN	21
3.2	CARRYING THE MANIKIN	22
3.3	TOWING THE MANIKIN	22
3.4	MANIKIN HANDLERS	23
4.	EVENT DESCRIPTIONS	24
4.1	OBSTACLE SWIM (200m and 100m)	24
4.1.1	Event description – 200m.....	24
4.1.2	Event description – 100m.....	24
4.1.3	Equipment.....	24
4.1.4	Disqualification	24
4.2	MANIKIN CARRY (50m)	25
4.2.1	Event description	25
4.2.2	Equipment.....	25
4.2.3	Disqualification	25
4.3	RESCUE MEDLEY (100m)	26
4.3.1	Event description	26
4.3.2	Equipment.....	26
4.3.3	Disqualification	26
4.4	MODIFIED RESCUE MEDLEY (50m)	27
4.4.1	Event description	27
4.4.2	Equipment.....	27
4.4.3	Disqualification	27
4.5	MANIKIN CARRY WITH FINS (100m)	28
4.5.1	Event description	28
4.5.2	Equipment.....	28
4.5.3	Disqualification	28
4.6	MANIKIN TOW WITH FINS (100m)	29
4.6.1	Event description	29
4.6.2	Equipment.....	29
4.6.3	Disqualification	30
4.7	SUPER LIFESAVER (200m)	31

4.7.1	Event description	31
4.7.2	Equipment.....	31
4.7.3	Disqualification	32
4.8	LINE THROW	34
4.8.1	Event description	34
4.8.2	Equipment.....	36
4.8.3	Disqualification	36
4.9	MANIKIN RELAY (4 x 25m)	37
4.9.1	Event description	37
4.9.2	Equipment.....	38
4.9.3	Disqualification	38
4.10	OBSTACLE RELAY (4 x 50m)	39
4.10.1	Event description	39
4.10.2	Equipment.....	39
4.10.3	Disqualification	39
4.11	MEDLEY RELAY (4 x 50m)	40
4.11.1	Event description	40
4.11.2	Equipment.....	41
4.11.3	Disqualification	41
4.12	FIN RELAY – MIXED (8 x 50m)	42
4.12.1	Event description	42
4.12.2	Equipment.....	42
4.12.3	Disqualification	42
4.13	DISQUALIFICATION CODES FOR POOL EVENTS	43
5.	COMPETITION ENTRY	46
5.1	Registration and Entry	46
5.2	Entry Processing	46
5.3	Electronic Entry Procedures and Responsibilities	46
5.4	Recording and Event Preparation	47
6.	Appendix A – State Championship Forms	48
	Event Team Change – Withdrawal / Substitution	48
	Protest Form	49
	Appeals Form	51

1. GENERAL RULES AND PROCEDURES

1.1 CONDUCT OF EVENTS

- (a) These Championships will be run in accordance with the ILS Competition Rule Book 2025 Edition (Issued August 2025, Effective September 1, 2025)
- (b) This document must be read in conjunction with the current National RLSSA Competition Handbook which also contains the current ILS rules.
- (c) All modified events must be run in accordance with the modifications outlined in this Competition Manual.
- (d) RLSNSW & SLSNSW expect the highest standard of conduct from its competitors, officials, and members. It is important that any competition or sports activity of the RLSNSW and/or SLSNSW Branch be conducted in the spirit of goodwill, sportsmanship, and fair play.
- (e) All participants required to abide by the RLSNSW & SLSNSW Behaviour Policies, Code of Conduct and compete within the rules. This includes following the expectations outlined in the RLSNSW Handbook Section 2 Member Protection Policies and SLSA Policy 6.05 Member Protection.
- (f) Competitors shall compete in competitions in the manner prescribed in the event rules with regard to course, method, procedures, and restrictions.
- (g) Competitors shall not interfere with, obstruct, or in any way willingly attempt to unfairly disadvantage another competitor nor shall the athlete compete in such a way as to gain an unfair advantage for themselves or another person.
- (h) Copies of all RLSNSW Branch Policies may be obtained from the Branch office and are also located on the RLSNSW website.
- (i) Copies of all SLSNSW Branch Policies may be obtained from the SLSA Member's portal.
- (j) This Competition handbook is a combination of three rulebooks, which are being used in conjunction with each other. For clarity, the main rulebook which will be used is the ILS Competition Rule Book 2025 Edition (Issued August 2025, Effective September 1, 2025) for all pool events. For modified events both the RLSNSW Handbook and Surf Life Saving Surf Sports Manual latest editions will be used.
- (k) For all Championship procedures the RLSNSW Handbook and in extension, the RLSSA Competition Handbook will take precedents over both the SLSA rulebook and ILS rulebook.

1.2 COMPETITION ORGANISATION AND PROCEDURES

(a) COMPETITION AREA

The competition area shall, where practical, be separated from the spectator area. The competition area shall contain:

- i. A marshalling area (with separate areas for marshalling and check starting).
- ii. Event course(s) suitably marked.
- iii. A recording area.
- iv. An announcing area.

The competition area should be set up to encourage a logical flow of competitors through the sequence of marshalling, competing, and recording.

(b) ENTRY

The entry procedure for all competitions is by standard electronic entry procedures using the Programs Meet Manager and Team Manager.

For clubs who do not have a full licensed copy of these programs, a free copy of Team Manager Lite is available for download at <https://hytek.active.com/downloads.html>

A full explanation of the entry procedure is detailed in the Championship Information and Entry Circular distributed to clubs.

(c) RELAY TEAM COMPOSITION

Teams where the age group is specific (e.g., U11/U12 relay or Open relay) the following is permitted:

- i. Teams aged below the Open competition classification may include competitors from the next lowest age classification.
- ii. Teams competing in the Open competition classification may include competitors from the U17 – Masters age classifications.
- iii. Teams are permitted to enter more than one (1) relay team per event, provided they meet the requirements.
- iv. The total number of team members out of the age classification shall not exceed 50% of the total number of competing team members within the age classification.

Non-specific gender relay teams – May be either all male, all female or a mixed team of both male and female.

Mixed Relay Teams This type of relay category must contain at least 25% male and 25% female competitors. Therefore, for a four (4) person team the requirement is one (1) team member and for an eight (8) person team the requirement is two (2) team members.

Reserves

No more than 50% of a team may be replaced from those officially entered. At entry all relay team members must be shown, and it is desirable that the entry also lists reserves. To ensure that substitutions meet the eligibility requirements for the event, a competitor will not be allowed to substitute for an original team member without the permission of the Chief Referee or Competition Manager, unless indicated on the entry form as a reserve.

1.3 WITHDRAWAL AND SUBSTITUTION

Notification of withdrawals and substitutions must be made prior to the start of the session or at least 1 hour (60 minutes) before the schedule starting time for that event. This announced time is set by the Competition Manager, in conjunction with the Chief Referee and Chief Recorder.

- (a) All withdrawals or substitutions in an event must be made in writing on the appropriate competition form and lodged with the designated official (Competitor Liaison).
- (b) Only the Team Manager may submit a substitution/withdrawal sheet.
- (c) Competitor withdrawals from individual events should be lodged as soon as possible but substitution of the competitors is not permitted.
- (d) In relay events the substitution of competitors is at the discretion of the team management so long as the entry and eligibility rules for the event are followed.

Competitors who are substituted in a relay event may only be replaced by another registered competitor from the same competitive team.

After the event substitution time has closed, there shall be no further alteration of relay entries in an event unless there is a demonstrated misadventure (e.g. injury) which prevented a substitution notification being lodged by the required time limit.

1.4 SAFETY

Consideration must be given to modifying the event conditions where risk assessment indicates that safety is compromised. If necessary, when rescue tubes are being used any exposed ends on starting grips, shall be covered.

- (a) OBSTACLE PLACEMENT: must be in made in accordance with ILS requirements.
- (b) STARTING PLATFORM: If necessary, any exposed ends on starting grips, etc., shall be covered. The height of the platform above the water surface shall be from 500mm to 750mm. The surface area shall be at least 500mm x 500mm and covered with non-slip material. The maximum slope shall not be more than 10 degrees. The starting platform may have an adjustable setting back plate and starting grips for both platform and in-water starts. For events with rescue tubes the starting platform and immediate surrounding area should be checked for hazards that may impede the rescue tube leaving the start area safely.
- (c) WATER: The pool water shall meet the clarity standards and the bacteriological and chemical standards under the local health regulations, consistent with the RLS Guidelines for Safe Pool Operations.

The starting and finishing for Pool events must take into consideration not only the event requirements but also the safety aspects. Risk management must be put into place.

1.5 COMPETITION CONDITIONS

In all events, the distances shall be in accordance with event descriptions and shall be conducted in lanes.

All events will be conducted as timed finals and the general FINA principles of judging, timekeeping & recording will be employed.

- (a) Where the number of entrants exceeds the number of lanes, an event shall be swum in heats and the final results shall be determined on the times swum in the heats and no final shall be swum.
- (b) Entry times are used to seed heats, the fastest competitor will swim from the middle lane with the next fastest swimmers allocated the next lanes out until all the lanes allocated have been used.
- (c) If no entry times are supplied to seed heats, there shall also be an equal distribution of clubs represented in each heat.
- (d) Electronic timing will be used for all events, including Line throw, however 3 place judges will also be used in line throw events. For all other events there is no requirement to use place judges when automatic timing is being used.
- (e) Wherever possible, as well as a Chief Timekeeper, there shall be two (2) timekeepers used to time each lane.
- (f) When handheld stopwatches are used, timekeepers shall keep a personal record of the times taken during the competition and record the event time on the recording sheet which is dispatched to the competition recorders.

- (g) The winner shall be the competitor judged to have reached and touched the finish wall or line first according to the official automatic recorded times or where manual times are used, according to the place judge order.
- (h) When AOE timing is not being used, events will be judged by at least three (3) Place Judges, one of who will be designated as the Chief Place Judge who will collate each judge's decision to arrive at a final result prior to the result being sent to the recording table.

1.6 GENERAL COMPETITION RULES

Team management and competitors are responsible for being familiar with the competition schedule, and with the associated rules and regulations governing events.

- (i) Freestyle means that in an event where freestyle is designated the swimmer may swim any style, unless otherwise specified in the event conditions.
- (j) Fins - Competitors may retrieve fins lost after the start and continue without disqualification so long as the rules governing manikins are not violated. Competitors are not permitted to start again in another heat.
- (k) Club Caps - Competitors are required to wear a designated club cap during pool competition as described on the club affiliation form. The cap may be the traditional lifesaving cap or the pull-on latex/ silicon type. **Members acting as manikin handlers for competitors are not required to wear a team cap.**
- (l) Competitors may not be permitted to start in an event if they are late reporting to the marshalling area. Officials are not responsible if a competitors or team are not in attendance for the start of a race or are improperly attired due to late arrival to marshalling.
- (m) A competitor or team absent from the start of an event may be disqualified. No protest or appeal is permitted by a competitor/team/handler if they are not in attendance for the start of a race or are improperly attired.
- (n) Only competitors and officials shall be allowed on the pool deck in the designated competition area. Competitors and officials must leave the designated competition area when not competing or officiating.
- (o) Unless specifically provided for in the rules, no artificial means of propulsion may be used in competition (e.g. hand webs, armbands).
- (p) The use of sticky, tacky or adhesive substances (liquid, solid or aerosol) on competitors' hands or feet, or applied to the surface of a manikin or rescue tube to improve grip, or to assist the competitor to push off the pool bottom, is not permitted in pool events.
- (q) Body tape used for preventative, medical or therapeutic/kinesiology purposes is allowed at the discretion of the referee so long as it does not provide a competitive advantage to improve grip, grasping or propulsion.
- (r) Competitors shall not take assistance from the pool bottom except where specifically allowed (e.g., Obstacle Swim, 4 x 25 m Manikin Relay).
- (s) Taking assistance from any pool fittings (e.g., lane ropes, steps, drains or underwater hockey fittings) is not permitted.
- (t) A competitor who interferes with another competitor during a race shall be disqualified.
- (u) The Chief Referee may permit the re-run/re-throw of a race due to equipment failure or because of interference. The re-run/re-throw time shall be the official time.
- (v) Order-of-finish decisions, whether by judges or automated timing equipment, are not subject to protest or appeal.

1.7 START AND FINISH PROCEDURES

1.7.1 Official Start and Completion of Competition

- (a) A competition is deemed to begin when a call for marshalling is officially issued by the competition organisers.
- (b) The official conclusion of a competition is 20 minutes following the competition event. However, issues under protest, appeal or disciplinary review shall completion of the last continue to final resolution which shall be deemed to fall within the official competition time.
- (c) All events the start line shall be the pool wall (A pool wall can be the pool edge or starting block attached to a pool wall).
- (d) A one start rule applies for all age groups. The exception is for 10-11(U11/U12) age groups where a 2 start rule applies.
- (e) The Starter/Event Director shall take control of the competitors from the Marshal or Check Starter.
- (f) The Starter shall state the event name, heat number and any safety/hazards identified, competitors should be aware of while competing in the event. The Starter may also be required to provide competitors with any other relevant information as directed by the Chief Referee.
- (g) The starting device shall be a device approved for the purpose by the Organising Committee.
- (h) Any person who seeks to gain an unfair advantage by starting before the Starter's intentional signal or who has gained an unfair advantage through their own actions, shall be disqualified.
- (i) After the intentional starting signal has been given a race will not be recalled unless the Starter or Chief Referee

decides that (Section 5.2 Starts) below should apply. If a competitor is deemed by the Starter or Chief Referee to have gained an unfair start, then that competitor shall be informed of their disqualification at the end of the race.

- (j) The Chief Referee will disqualify competitors who intentionally delay a start, cause an intentional false start, or enter the water before the intentional starting signal has been given. They will be removed from the starting line-up.

1.7.2 Starts

- (a) The starting of all Championship events is the responsibility of the Starter.
- (b) The duty of the Event Director and starter is to ensure a fair start. If the starter or Event Director decides that a start is not fair, for any reason, including technical or equipment fault, the competitors shall be called back, and the race shall be started again.
- (c) For all under 11- and 12-year-old age division events if, in the opinion of the Starter, the start has been unfair, they shall recall the competitors by a second signal from the starting device or a whistle blast.
- (d) The starter or Event Director uses their discretion in determining whether a competitor (or more than one competitor) has commenced a starting motion. Commonly, the early starting motion of one competitor causes movement by other competitors. Such movements are not a disqualification.
- (e) The Starter's or Event Director's decisions on starts are not subject to protest or appeal.

1.7.3 Start Procedure

The definition of a start, unless otherwise defined in an event description is as follows.

Prior to the start of each race, the Event Director or designated officials shall:

- (a) Check that all technical officials are in position.
- (b) Check that competitors, manikin handlers and victims are properly attired and in correct positions.
- (c) Check that all equipment is in a safe and correct position.
- (d) Notify competitors to remove all clothing except for swimwear, position their equipment, if required, and get ready to race. **This may be done by three short whistle blasts.**
- (e) When competitors and technical officials are ready for a legal start, the Event Director shall:
 - i. Signal the official start of each race with a long whistle indicating that the competitors should take their position on the starting platform or enter the water.
 - ii. Signal the starter (that the competitors are under the starter's control) with an outstretched arm in the direction of the course.

Note 1: At the discretion of the Chief Referee "over the top" starts may be used.

Note 2: Provided that the correct marshalling procedures and the above start procedure is used, officials are not responsible if a competitor, team or handler are not in attendance or ready for the start of a race. No protest is permitted.

1.7.4 Dive Start Procedure

- (a) Competitors may start on the starting platform, on the pool deck, or in the water with one hand in contact with the starting wall.
- (b) On the long whistle competitors' step onto the starting platform and remain there.
- (c) On the starter's "Take your mark" command, competitors immediately assume a starting position with at least one foot at the front of the starting platform. When competitors are stationary, the starter gives the acoustic starting signal.

1.7.5 In Water Start Procedure

The Line Throw and Manikin Relay events begin with an in-water start as follows:

- (a) On the first long whistle, the competitors in the manikin relay and line throw victims enter the water and prepare for the start.
- (b) At the second long whistle, competitors take their positions for the start without undue delay.
- (c) When all competitors have assumed their starting positions, the Starter shall give the command "Take your mark."
- (d) When all competitors are stationary, the Starter gives the acoustic starting signal.

1.7.6 Manikin Relay Start

The Manikin Relay start conditions are as follows:

- (a) All competitors must have entered the water in the respective positions before the second whistle can be given.
- (b) The first competitor starts in the water holding a manikin at the surface with one hand and the pool edge or starting block with the other hand.

1.7.7 Line Throw Start

The Line Throw event conditions are as follows:

- (a) The in-water entry by the victim and a deck start by the competitor
- (b) On the first whistle, the competitor and victim step into the throw zone.
 - i. The thrower (competitor) holds one end of the throw line.
 - ii. The victim takes the line, enters the water and extends the surplus line over and beyond the crossbar/line in the allotted lane.
 - iii. No practice throws are permitted.
- (c) The victim treads water on the near side of the rigid crossbar in the allocated lane & must hold onto the cross bar.

Note: See event description for the more detailed start procedure for Line Throw

1.7.8 Start Disqualifications

Start decisions by the Starter or Event Director are not subject to protest or appeal.

- (a) All competitors who start (i.e., commence a starting motion) before the starting signal has been given, shall be disqualified.
- (b) If the disqualification is declared after starting signal, the race shall continue, and the competitor(s) shall be disqualified upon completion of the race.
- (c) If the disqualification is declared before the starting signal, the signal shall not be given, and the competitor involved will be informed of their disqualification and shall be removed from the starting line-up. The remaining competitors shall be called back to start again.
- (d) The signal to call back the competitors shall be the same as the starting signal but repeated, along with dropping of the false start rope. Alternatively, if the Chief Referee or Chief Referee's designate decides that the start is not fair, then they shall blow a whistle, to be followed by the Starter's signal (repeated).
- (e) For the 100 m Manikin Carry with Fins event, the call-back signal will be by an underwater acoustic signal whenever possible. Competitors will be advised if an alternate call back signal is used.
- (f) If installed on starting blocks, the electronic pressure system may be used to assist adjudication on starting and relay changeover breaks.

1.7.9 Start Modifications - Equipment

For full details of equipment requirements and specifications refer RLS-A– Competition Handbook Section 9 - Facility and Equipment Standards for Pool Lifesaving Competition.

The following equipment is required for the events outlined in these Rules and will be supplied by organisers:

- (a) Obstacles
- (b) Throw line: The throw line must be between 16.5 m and 17.5 m in length.
- (c) Manikin: The definition of a half full manikin is that the manikin is filled with water, so that when positioned vertically it floats with the top of its transverse line at the surface.

1.7.10 Turns

- (a) Each lap will finish when the competitor touches the pool wall with a part of their body unless otherwise provided by in an event description.
- (b) Tumble turns are permitted unless restricted in an event description.
- (c) If an event is shorter than the pool dimensions then each lap will finish when the competitor touches, with any part of their body, the designated rope or marker as specified in the event description.
- (d) Competitors are required to stay wholly within their lanes for the entire race and are not to interfere with any other competitor while the event is in progress.

1.7.11 Finish

- (a) Competitors shall be disqualified if they fail to affect the touch within the required definition for the particular event.
- (b) Competitors are required to remain in the water until dismissed by a blast from a whistle or an instruction from the Chief Referee or designated official.
- (c) When dismissed competitors must exit the pool sides, not by the pool end over timing pads and by the shortest route. They are not to interfere with any official or official equipment while doing so.

1.8 COMPETITION ELIGIBILITY

1.8.1 Competition Qualification

To be eligible to compete in this Championship competition all members must, by the close of normal entries for the relevant Championship:

- (a) Be a registered and current financial member of SLSA and/or RLSNSW
- (b) Be the holder of the appropriate SLSA / RLS award relevant to the age category as detailed in the current edition of the RLSNSW Handbook or Surf Sports Manual or hold the equivalent overseas ILS member country award.
- (c) Be RLSNSW or SLSA proficient as prescribed for the relevant RLS or SLSA Award required for competition eligibility as at the normal closing date of entries.
- (d) Be eligible under the necessary age category.
- (e) Not be in default with their Club, Branch, State Centre or SLSA (or overseas ILS member associations) in relation to their service, financial or discipline obligations.
- (f) **Note 1 SLSA Only:** Have met their patrol and/or service commitments as detailed in SLSA Competition Eligibility Policy 5. 04 and required by their Club, Branch, State and SLSA.
- (g) **Note 2: SLSA Only.** Masters competitors over the age of 50 years who wish only to compete in Masters championship competition must hold a SLSA Bronze Medallion and a current Bronze Medallion proficiency as detailed in SLSA Competition Eligibility Policy 5.04 except that these members may have an extended run swim run time of 12 minutes. This extended run swim run time limit for Masters competitors over the age of 50 years will not requalify a member to be eligible to undertake Bronze Medallion patrol duties.

1.8.2 Determining Age Groups

To determine an age group, all competitors must have a common birth date calculated as on/at midnight on 1st January of the year that the Championships will be held, i.e. age at midnight on 1st January determines the competitor's age category (for individual events) in this Championships.

Age Groups & Gender

- (a) NSW Pool Lifesaving competition events shall be conducted in the following age group categories:
 - 10-year-olds (Under 11)
 - 11-year-olds (Under 12)
 - 12-year-olds (Under 13)
 - 13-year-olds (Under 14)
 - 14-year-olds (Under 15)
 - 15–16-year-olds (Under 17)
 - 17–18-year-olds (Under 19 years)
 - Open (19 years+)
 - Masters (30 years+)
- (b) Competitors compete according to their age on/at midnight on 1st January of the year that the Championships will be held. Outlined below are the proficiency awards required for each age group.
- (c) Competitors must be **10 years old** midnight on 1st January of the year that the Championships will be held to be eligible to compete.

Minimum Proficient Award to Complete		
Age Group	RLSNSW	SLSNSW
Individual Events		
10-year-olds (Under 11)	S&S Level 8 (SS8)	Provided they are currently proficient in the appropriate age award for their surf age group
11-year-olds (Under 12)	S&S Level 8 (SS8)	Provided they are currently proficient in the appropriate age award for their age
12-year-olds (Under 13)	RLSSA Bronze Star	Provided they are currently proficient in the appropriate age award for their age
13-year-olds (Under 14)	RLSSA Bronze Star	SLSA Surf Rescue Certificate or U13 preliminary evaluation
14-year-olds (Under 15)	RLSSA Bronze Star	SLSA Surf Rescue Certificate

15–16-year-olds (Under 17)	RLSSA Bronze Medallion	SLSA Bronze Medallion/Certificate II
17–18-year-olds (Under 19)	RLSSA Bronze Medallion	SLSA Bronze Medallion/Certificate II
Open	RLSSA Bronze Medallion	SLSA Bronze Medallion/Certificate II
Masters	RLSSA Bronze Star/RLSSA Bronze Medallion	SLSA Bronze Medallion/Certificate II
Relay Events		
10-11 years (U11/U12)	S&S Level 8 (SS8)	Provided they are currently proficient in the appropriate age award for their age
12-13 years (U13/U14)	RLSSA Bronze Star	Provided they are currently proficient in the appropriate age award for their Age / SLSA Surf Rescue Certificate or U13 preliminary evaluation
14-16 years (U15/17)	(14 yrs) RLSSA Bronze Star (15-16 yrs) RLSSA Bronze Medallion	SLSA Surf Rescue Certificate/ SLSA Bronze Medallion
17-18 years (U19) / Open / Masters	(U19/Open) RLSSA Bronze Medallion (Masters) RLSSA Bronze Star	SLSA Bronze Medallion/Certificate II

1.8.3 Participation in Individual and Team Events

- (a) Competitors may only compete in **one age group per individual event**, with the exception of U17, U19 and Masters, who may compete in their own age group **and** in the Open age group.
- (b) Competitors may only complete in **one relay team per age group event**.

1.9 CODE OF CONDUCT

1.9.1 Code of conduct for competitors, technical officials and members

ILS competitions are high profile public events. ILS expects all competitors, officials and members to co-operate to ensure a positive public image. Behaviour likely to cause embarrassment or damage to the image of ILS or lifesaving competition will be referred to the Disciplinary Committee. Penalties may include expulsion of individuals or teams from the competition. ILS expects the highest standard of conduct of its competitors, officials and members. These expectations are reflected in the rules for competition in the ILS constitution and this rule book.

For the purpose of applying the code of conduct, the definition of a 'team' includes actual competitors, coaches, assistants, spectators, etc., travelling with the team. Violations of this code will result in individual and/or team disqualification from the competition.

1.9.2 Fair-play code for lifesaving competitions

It is important that competition, especially world championships, be conducted in a spirit of goodwill and sportsmanship. Competitors are required to abide by and compete within the rules. Any breach of the rules will be reported to the Chief Referee who may initiate action as described in 1.9.3 Misconduct.

Team members represent their country, their organisation, their club, their sponsors and ILS. As such, team members shall at all times conduct themselves in a proper and civil manner during the championships and related activities including social functions. Unbecoming conduct by a team or its supporters is a serious offence and will be dealt with as such. Any action by a team which attempts to disrupt or interfere with another team is a serious offence and will be dealt with as such.

The general conduct of all participants will be measured by the following ILS *code of fair play*:

- (a) **ILS will:**
 - Promote and encourage fair play through its members.
 - Impress upon competitors, coaches, technical officials and administrators the need to maintain the highest standards of sportsmanship and good behaviour in lifesaving sport.
 - Ensure that its rules are fair, clearly understood by competitors, coaches, technical officials and administrators, and properly enforced.
 - Make every effort to ensure that its rules are applied consistently and impartially.
 - Treat all members equally, regardless of their sex, gender identity, intersex status, sexual orientation, age, ability, race or physical characteristics, etc.
 - Make all reasonable provision to accommodate competitors with disabilities provided that there is no competitive disadvantage to other competitors in the event being contested.

- (b) **ILS technical officials will:**
- Abide by the rules and the spirit of the competition.
 - Be honest, fair and ethical in dealing with others.
 - Be professional in appearance, action and language.
 - Resolve conflicts fairly and promptly through established procedures.
 - Maintain strict impartiality.
 - Maintain a safe environment for others.
 - Be respectful and considerate of others.
 - Be a positive role model.
- (c) **Competitors will:**
- Abide by the rules and the spirit of the competition.
 - Treat officials with respect and accept the decisions of Referees and Judges without question or complaint.
 - Never consider cheating and in particular, not attempt to improve their individual performance by the use of drugs.
 - Exercise reasonable self-control at all times.
 - Accept success and failure, victory and defeat, with grace and magnanimity.
 - Treat their fellow competitors and team members with respect, both in and outside the competition arena.
- (d) **Team managers and coaches will:**
- Insist that competitors understand and abide by the principles of fair play.
 - Never countenance the use of drugs by competitors.
 - Never employ methods or practices that could involve risks, however slight, to the long- term health or physical development of their competitors.
 - Not attempt to manipulate the rules in order to take advantage of their competitors or their opponents.
 - Respect the regulations and authority of ILS and its member organisations and not attempt to avoid or circumvent these regulations.
 - Recognise the special role that they have to play in ILS and set a good example of sportsmanship and good behaviour at all times.
 - Respect the rights of other teams and never deliberately act in a manner intended to be to the detriment of another team.
 - Respect the rights of competitors, coaches, technical officials and not exploit or deliberately act in a manner detrimental to them.
 - Not endeavor to influence the result of a competition by any action not strictly within the rules and regulations or within the fundamental precepts of fair play.
- (e) **Delegates, media representatives, supporters and spectators will:**
- Respect the authority and regulations of ILS and not attempt to avoid or circumvent them.
 - Accept the authority of technical officials.
 - Abide by the spirit of the competitions.
 - Exercise reasonable self-control and display good behaviour at all times.
 - Be respectful and considerate in interactions with others.
 - Acknowledge the performance of all involved in the competition with grace and magnanimity.

1.9.3 Misconduct

Conduct and discipline generally ILS, either by pre-determined publicised penalties or by adopting the decision of a disciplinary committee, may, at its discretion, issue penalties to individual competitors, clubs or national teams.

Competing unfairly

- (a) Competitors or teams who are deemed to have competed unfairly may be disqualified from an event or expelled from the championships. The Chief Referee may refer the competitor or team to the disciplinary committee for consideration of further penalty. Examples of competing unfairly include:
- Committing a doping or doping-related infraction.
 - Impersonating another competitor
 - Competing twice in the same individual event.
 - Competing twice in the same event in different teams.
 - Purposely interfering with a course to gain an advantage.
 - Competing without entry.
 - Competing for another club or nation without federation clearance.
 - Attempt to defeat the ballot or draw for events or positions.
 - Competing using equipment that does not meet ILS specifications.
 - Competing contrary to the specific direction of the Chief Referee or designated official

- Jostling or obstructing other competitors or handlers so as to impede their progress.
 - Receiving physical or material outside assistance (other than verbal or other direction except where specifically excluded by the rules of the event).
 - Participating contrary to the spirit of the competition (as described in the code of fair play).
- (b) The Chief Referee and/or the relevant technical official(s) shall have absolute discretion in determining whether a competitor, team or handler has competed unfairly.
- (c) ILS may, in its absolute discretion, investigate and take action on any matter of “competing unfairly” prior to, during or following competition. This includes, not limited to, the return of medals and referral to the disciplinary committee.

Serious discipline offence

- (a) If a competitor or team commits what could be a serious discipline offence, they should immediately contact the Organising Committee and detail the circumstances. Failure to report a possible violation is itself an offence against ILS rules.
- (b) Allegations of a serious discipline offence shall be referred to the Disciplinary Committee.
- (c) If the Chief Referee disqualifies a competitor or team for a serious offence in competition, the Chief Referee may also choose to make a report to the Disciplinary Committee which may decide to apply a further penalty against the competitor or team and its members.

Disciplinary Committee

- (d) The Organising Committee shall appoint a Disciplinary Committee consisting of no less than 3 members.
- (e) The host organising committee shall supply the Disciplinary Committee with the name, contact address and phone number at the competition site of the manager of every participating team.
- (f) The Disciplinary Committee shall inquire into any written complaint of misconduct or any matter referred to it by the Appeals Committee or Chief Referee.
- (g) The committee may also initiate an inquiry to determine if an offence has been committed and make a complaint if appropriate. The committee may then proceed as if another person had made the complaint.
- (h) The committee may assign appropriate penalties including removal from or disqualification from the championships and forfeiture of titles or trophies.
- (i) The committee shall report in writing on its inquiries and decisions to the ILS Secretary General.
- (j) Complaints must be received in writing or the complainant must be prepared to attend a meeting or inquiry of the committee as and when required.
- (k) The member or members against whom the complaint is made shall be entitled to be present at every hearing accompanied by the team manager.
- (l) All persons involved in a disciplinary hearing or enquiry or an Appeals Committee hearing, must abide by and strictly observe the ILS Code of Conduct set out in this Section. In particular, but without limitation, all persons involved in such hearings or enquires must:
- Be honest, fair and ethical.
 - Be respectful and considerate of others.
 - Exercise reasonable self-control at all times.
 - Be truthful and treat all persons involved in good faith and with courtesy and respect.
- (m) Inquiry guidelines:
- Formal rules of evidence will not apply to the hearing or enquiry, but all persons involved must be truthful and act in good faith.
 - The complaint or reference to the committee shall be read to the competitor(s) or to the team(s') representative(s).
 - The evidence of the complainant shall be presented.
 - The evidence of the team member(s) against whom the complaint has been made shall be presented.
 - Each witness shall be subject to examination by the party (if any) on whose behalf the witness is called and then to cross-examination by the opposing party or parties. The party calling the witness shall have the right to re-examination, but no other examination shall be allowed except by leave of the committee.
 - Hearsay and irrelevant evidence shall not be admitted.
 - Witnesses other than the party charged shall remain out of hearing of the inquiry until called upon to give evidence.

2. POOL LIFESAVING SPEED EVENTS

2.1 GENERAL

Swimming pool based competitions are conducted by many fellow member countries of the International Life Saving Federation (ILS). Pool Lifesaving Competitions are included in the suite of events conducted in ILS World Life Saving Championships and other international competitions. The conduct of Pool Lifesaving Competitions also provides a further avenue, outside of the ocean environment, for activity participants to develop and to demonstrate their lifesaving and or organisational skills.

NSW has adopted specific sections of ILS Pool Lifesaving Rules and equipment as the standard for the conduct of its Pool Lifesaving Competitions.

To enable the conduct of competition, the following areas of the ILS Competition Manual have been specifically adopted by SLSA and RLSSA:

- ILS World Record Principles and Procedures
- Wearing of Swim Caps in Pool Events, Simulated Emergency Response Competition
- ILS Pool Events Event Rules
- ILS Facility Standards – Pool Facility Standards and specifications
- ILS Equipment Standards and Scrutineering for Pool Manikins, Obstacles, Rescue Tubes, Swim Fins and Throw Lines.

Except where otherwise provided for in this document, the current RLSNSW Handbook and SLSA SSM and subsequent bulletins or circulars shall apply for all other matters relating to conduct of the NSW Pool Lifesaving Competitions.

2.2 SPEED EVENTS AND THEIR PURPOSE

- (a) **LINE THROW** - To test the speed and ability of a competitor to perform a rope throw rescue effectively. To develop effective technique, skill and efficiency to perform a throw rescue under pressure.
- (b) **OBSTACLE SWIMMING** - To test a competitor's ability to swim and submerge at speed using skills required for surface dive, object retrieval as well as to enter/escape from submerged vehicle or boat.
- (c) **MANIKIN EVENTS** - To test a competitor's speed when towing or carrying a patient. Manikins are used to ensure all competitors tow under similar conditions. To develop an individual's effective technique and skill to perform an effective rescue, as well as develop a sound knowledge in regard to their personal capability.

2.3 SPECIAL CONDITIONS FOR NSW COMPETITIONS

2.3.1 Swim Fins Specifications for U13 and Under Age Category Events

The swim fins used in events for U13 and under aged events are restricted to soft/flexible rubber type fins used for swimming training similar to the styles depicted below:



Please note that fins that do not meet this general profile or are for the specific purpose of diving or surfing/ bodyboarding and/or with stiff and/or elongated blades, will not be permitted for use in U13 and under events.

- (a) The swim fins shall comply with the following dimensions:
- (b) Maximum 50cm overall length including the shoe.
- (c) Maximum 25cm width at the widest point of the blade.
- (d) Swim fins are to be measured with the shoe or ankle strap extended but not stretched. Swim fins will not be permitted to be used if they do not conform to the specifications or if they are considered to be a safety hazard.

Note: Fins are measured while not being worn.

2.3.2 Swim Fins Specifications for U14 and Over Age Category Events

The swim fins used in events for U14 and over aged events must meet ILS requirements and may be constructed of rubber, composite or other materials in the style depicted below:

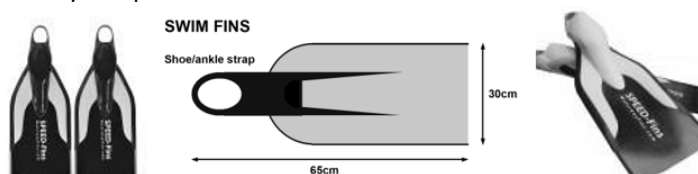

- (a) The swim fins shall comply with the following dimensions:
 - i. Maximum 65cm overall length including “shoe” or ankle strap (ankle strap extended).
 - ii. Maximum 30cm width at the widest point of the blade.
- (b) Swim fins are to be measured with the shoe or ankle strap extended but not stretched. The swim fins will not be permitted to be used if they do not conform to specifications or if they are considered a safety hazard.
- (c) Swim fins are to be measured with the shoe extended but not stretched. Swim fins will not be permitted to be used if they do not conform to the specifications or if they are considered to be a safety hazard.

Note: Fins are measured while not being worn.

Note: U14 competitors may use fibreglass fins in individual events only and must wear rubber fins in all team relay events where combined with the U13 age group (i.e. U13/U14 Medley Relay).

2.3.3 Rubber Bricks Specifications

- (a) The rubber bricks to be used in specific U14 Brick Carry events and all U13 and under Brick Carry events have the following specifications:
 - i. Measurements: 230mm x 80mm x 80mm
 - ii. Weight: 3.5kg
 - iii. The bricks shall have a profile similar to the style depicted below:



2.4 SPECIFIC NSW EVENT RULES

NSW, at its discretion, may conduct events other than those contained in the ILS Competition Rule Book at its competitions. The below events are all modified NSW events. All events below affect the U11 – U14 age groups, and the 50m Freestyle with fins affects U11s – Masters age groups.

- 50m Freestyle Swim with fins
- 50m Brick Carry
- 4x25m Brick Relay
- 100m Brick Carry
- 100m Manikin Carry (empty manikin)
- 50m Manikin Tow
- 4x50 Medley Relay (U11/U12 & U13/U14)

2.4.1 50m Freestyle Swim with Fins

- (a) With a dive entry on an acoustic signal, the competitor swims 50m freestyle with fins.

Note: “Freestyle” means that in an event so designated the swimmer may swim any style including form strokes and underwater.
- (b) Following the dive entry, the competitor may swim underwater for the entire 50m.

Note: There is no requirement to surface, but it is advisable that competitors finish at a depth that allows electronic timing to be activated.
- (c) The event is completed when the competitor touches the finish edge of the pool.
- (d) **Equipment:**
 - U13 and underage competitors must use rubber type fins as specified in Section 2.3.1.
 - U14 age competitors and over competitors are permitted to use the ILS specification composite type fins, as specified in Section 2.3.2.
- (e) **Disqualification:**

In addition to the General Conditions for disqualification contained in the current SLSA SSM and any specific or amending competition bulletins and circulars, the following behaviour shall also result in disqualification:

 - A false start as detailed in 1.7 Start and Finish Procedures
 - Failure to touch the finish wall.

2.4.2 50m Brick Carry

- (a) With a dive entry on an acoustic signal, the competitor swims 25m freestyle and then dives to recover a submerged rubber brick to the surface within 5m of the pick-up line.
- U11 Modification Only: Competitor swims 35m and then dives to recover a submerged rubber brick to the surface within 5m of the pick-up line.
- (b) The competitor then carries the rubber brick to touch the finish edge of the pool.
- (c) The event is completed when the competitor touches the finish edge of the pool.
- (d) **Equipment:**
- Rubber brick, as per the specifications in Section 2.3.3.
Note: Unless otherwise specified, competitors must use the rubber bricks supplied by the Competition Organisers.
- (e) Positioning of the brick:
- The brick is placed at the 25m (or 35m for U11) mark with a 5m pick up zone marked by cones on the pool edge.
 - The rubber brick is located at a depth between 1m and 3m. In water deeper than 3m, the brick shall be placed on a platform (or other suitable support).
- (f) Surfacing the Brick:
- Competitors may push off the pool bottom when surfacing with the brick.
 - Competitors must have the brick in the correct carrying position (see next heading) before the brick passes the relevant 5m line.
- (g) Carrying the Brick:
- A rubber brick is not classified as a “living object” and therefore it may be carried above or below the surface of the water as follows:
 - The brick must be carried not pushed. Pushing means the brick is held forward of the competitor’s head
 - The brick must be carried with one or two hands.
- (h) **Disqualification:**
- In addition to the General Conditions for disqualification contained in the current SLSA Surf Sports Manual, the current edition ILS Competition Rule Book and any specific or amending competition bulletins and circulars the following behaviour shall also result in disqualification:
- i. A false start as detailed in 1.7 Start and Finish Procedures
 - ii. Not surfacing before diving to the brick.
 - iii. Taking assistance from any pool fitting (e.g., lane ropes, steps) when surfacing with the rubber brick (not including the bottom of the pool).
 - iv. Not having surfaced with the rubber brick before the competitor’s head passes the 5m line.
 - v. Pushing the brick (above the head of the athlete).
 - vi. Not carrying the brick in one or both hands.
 - vii. Releasing the rubber brick before touching the finish edge/wall.
 - viii. Failure to touch the finish edge/wall.

2.4.3 4 x 25m Brick Relay

- (a) Four (4) competitors in turn carry a rubber brick approximately 25m each.
- (b) **Equipment:**
- The event is conducted on a similar basis as the 50m Brick Carry and with the same procedures as the 4 x 25m Manikin Relay but using a rubber brick instead of a plastic manikin.
- Note:** The first competitor may hold the brick in front of them at the start but must maintain contact with the brick with at least one hand at all times and have the brick in the correct carrying position at the 5m line.
- (c) **Disqualification:**
- In addition to the General Conditions for disqualification contained in the current SLSA SSM and any specific or amending competition bulletins and circulars, the following behaviour shall also result in disqualification
- (i) A false start as detailed in 1.7 Start and Finish Procedures
 - (ii) Taking assistance from any pool fitting (e.g., lane ropes, steps) when surfacing with the rubber brick – not including the bottom of the pool.
 - (iii) Pushing the brick (above the head of the athlete)
 - (iv) Not carrying the brick in one or both hands.
 - (v) Releasing the brick before the next competitor has grasped it (i.e., one hand of each competitor must be in contact with the brick).
 - (vi) Assistance from a third competitor during the exchange between the incoming and outgoing competitors.
 - (vii) Releasing the rubber brick before touching the turning wall or finish wall.

- (viii) Releasing contact with the turn edge/wall or starting block before the previous competitor has touched the edge/wall.
- (ix) One competitor completing two or more legs of the event.
- (x) Failure to touch the finish edge/wall.

2.4.4 100m Brick Carry with Fins

This event is the same as the 100m Manikin Carry with fins except the manikin is substituted for a rubber brick.

This is an U13 and U14 event only.

- (a) With a dive start on an acoustic signal, the competitor swims 50m freestyle wearing fins and then recovers a submerged brick to the surface within 10m of the turn wall.
- (b) The competitor carries the brick to touch the finish wall/edge of the pool.
- (c) Competitors need not touch the turn wall/edge of the pool. Competitors may push off the bottom when surfacing with the brick.
- (d) Equipment:
 - Rubber brick, as per the specifications in Section 2.3.3.
Note: Unless otherwise specified, competitors must use the rubber bricks supplied by the Competition Organisers.
 - Fins, must comply with the specifications in Section 2.3.1 and 2.3.2
- (e) Positioning the brick:
 - The brick is located at a depth between 1.8 m and 3m. In water deeper than 3m, the brick shall be placed on a platform (or other support) to position it at the required depth.
 - The brick is positioned so that it is contact with the pool bottom and its base touching the pool wall
 - Where the facility design does not provide a vertical wall that joins the bottom at 90 degrees, the brick must be positioned as close as possible to the wall, but no further than 300mm from the wall as measured at the water surface.
- (f) Surfacing the Brick:
 - Competitors must have the brick in the correct carrying position before the top of the brick passes the 10m line.
- (g) Retrieving lost fins:
 - Competitors may retrieve fins lost after the start and continue without disqualification as long as the rules governing Bricks are not violated (see Section 3 – *Manikins*).
 - Competitors are not permitted to start again in another heat.
- (h) Disqualification

In addition to the *General Rules* the following behaviour shall result in disqualification:

 - (i) Taking assistance from any pool fitting (e.g., lane rope, steps, drains or underwater hockey fittings) when surfacing with the brick – not including the bottom of the pool.
 - (ii) Not having the brick in the correct carrying position before it passes the 10m line.
 - (iii) Using an incorrect carrying technique as described in Section 3 – *Manikins*.
 - (iv) Releasing the brick before touching the finish wall/edge.
 - (v) Failure to touch the finish wall/edge.

2.4.5 100m Manikin Carry with Fins (empty manikin)

This event is the same as the 100m Manikin Carry with fins except the full manikin is substituted for an empty manikin.

This is an U12 and U11 event only.

- (a) With a dive start the competitor swims 50m freestyle wearing fins and then collects a manikin held by a handler at the turn wall.
- (b) The competitor carries the manikin to touch the finish wall of the pool.
- (c) Competitors do not need to touch the turn wall of the pool.
- (d) **Handlers:** The manikin handler is to hold the manikin using at least one hand, positions and holds the manikin upright, with the base of the manikin facing the turning wall, and floating at its natural buoyancy position anywhere within the allotted lane. The manikin handler may let go of the manikin after the competitor has touched the turning wall but must release contact with the manikin when the competitor grasps the manikin.
- (e) Equipment
 - Manikins: The manikin is empty of with water and sealed for the event.
Note: Competitors must use the manikins supplied by organisers.
 - Fins: Swim fins must comply with the specifications in Section 2.3.1 and 2.3.2
- (f) Positioning the Manikin:

- The manikin is held by a handler at the turn wall, held in position with the handlers hands above the water and clearly visible.
- (g) Turning with the Manikin:
- Competitors must have the manikin in the correct carrying position before the top of the manikin's head passes the 10m line after the turn wall.
- (h) Retrieving lost fins:
- Competitors may retrieve fins lost after the start and continue without disqualification as long as the rules governing manikins are not violated (see Section 3 – *Manikins*).
 - Competitors are not permitted to start again in another heat.
- (i) Disqualification
- In addition to the General Rules the following behaviour shall result in disqualification:
- (i) Taking assistance from any pool fitting (e.g., lane rope, steps, drains or underwater hockey fittings) when surfacing with the manikin – not including the bottom of the pool.
 - (ii) Not having the manikin in the correct carrying position before it passes the 10m line
 - (iii) Using an incorrect carrying technique as described in Section 3 – *Manikins*
 - (iv) Releasing the manikin before touching the finish wall/edge
 - (v) Failure to touch the finish wall/edge

2.4.6 50m Manikin Tow with Fins

This modified event is conducted over 50m, but the remainder of the event is unchanged from the 100m Manikin Tow with fins i.e., a half full manikin is towed 25m after a 25m approach.

This is an U13 and U12 event only.

- (a) With a dive start the competitor swims 25m freestyle wearing fins and a rescue tube and then collects a manikin held by a handler at the 25m mark of the pool.
- (b) The competitor touches the rope, collects the manikin, turns back towards the direction in which they swam and carries the manikin to touch the finish wall of the pool.
- (c) Competitors must touch the rope prior to touching the manikin
- (d) Handlers – For all events where the manikin is positioned at the 25m mark the same handling rules apply as for a 100m Manikin Tow but with the following conditions. Before the start of the race, the manikin handler positions themselves in the water and behind the 25m marker line. The hands of the handler must be above the water when holding the manikin at the 25m marker line.
- (e) Equipment
 - Manikins: The manikin is filled to halfway with water so that it floats with the top of its transverse line at the surface. Competitors must use the manikins supplied by organisers.
 - Rescue tube: Competitors must use the rescue tubes supplied by organisers.
 - Fins: Swim fins must comply with the specifications in Section 2.3.1 and 2.3.2
- (f) Positioning the manikin:
 - A member of the competitor's team assists as manikin handler. With the Chief Referee's approval, non-team members may act as handlers, provided they are registered in the competition in some capacity.
 - Before the start and during the race, the manikin handler positions the manikin – vertically and facing the turn rope at its natural buoyancy position – **the manikin may be positioned anywhere within the allotted lane**
 - The handler releases the manikin immediately after the competitor touches the turn rope. The handler may not push the manikin toward the competitor or the finish wall.
 - Manikin handlers are required to be in the water during this event.
- (g) Starts with rescue tubes:
 - At the start, the rescue tube and rescue tube line may be positioned at the competitor's discretion, but within the competitor's allotted lane. Competitors should ensure a safe and correct position of rescue tube and line. The rescue tube remains unclipped until secured around the manikin.
- (h) Wearing rescue tubes:
 - Rescue tubes must be donned correctly, either with the loop over one or two shoulders, or over the shoulder and across the chest – at the competitor's discretion.
 - Assuming the rescue tube was donned correctly, there is no cause for disqualification if the loop falls down on the competitor's arm or elbow during the competitor's approach to the manikin or during the manikin tow.
- (i) Securing the manikin:
 - After first touching the 25m marker line, the competitor then secures the manikin correctly with the rescue tube around the body and under both arms of the manikin, and clipped to an O-ring, within the 10m clip-up zone.

- Competitors may go back into the 10m clip-up zone to re-secure the manikin provided the manikin's head has not passed the 10m line.
- (j) Towing the manikin:
- Competitors must tow the manikin as detailed in Section 3 – *Manikins*.
 - The rescue tube must be attached to the manikin and the line of the rescue tube must be fully extended by the time the top of the manikin's head passes the 10m line.
- (k) Retrieving lost fins:
- Competitors may retrieve fins lost after the start and continue without disqualification as long as the rules governing manikins are not violated (see Section 3 – *Manikins*).
 - Competitors are not permitted to start again in another heat.
- (l) Rescue Tube Defect:
- If in the opinion of the Chief Referee the rescue tube, line and/or harness (belt) presents a technical defect during the race, the Chief Referee may allow the competitor to start again in another heat but only if the rescue tubes for the event were supplied by the organising body and the rules required that the provided tubes must be used by all competitors.
- (m) Disqualification
- Competitors shall be disqualified if the rescue tube and manikin become separated. Competitors shall not be disqualified if the rescue tube slips from under one arm of the Manikin during the tow, provided that the rescue tube was "secured correctly" at the 10m line and the face of the manikin remains above the water surface.
 - Competitors shall be disqualified if the line of the rescue tube is or becomes wrapped around the Manikin as it is deemed to be shortening of the line.
 - Competitors shall not be disqualified if the manikin rotates in the rescue tube as long as the manikin's face remains above the surface of the water. The manikin does not need to be carried headfirst provided it was secured correctly at the 10m line and the manikin's face remains above the surface of the water.
- In addition to the *General Rules* the following behaviour shall result in disqualification:
- (i) Taking assistance from any pool fitting (e.g., lane rope, steps, underwater hockey fittings) when fixing the rescue tube around the manikin except where the minimum pool depth allows the competitor to stand while securing the rescue tube around the manikin.
 - (ii) Competitor clipping the rescue tube into the ring before touching the 25m marker line.
 - (iii) Manikin handler not releasing the manikin immediately after the competitor has touched the 25m marker line
 - (iv) Manikin handler pushing the manikin towards the competitor or the finish wall/edge
 - (v) Manikin handler positioning the manikin incorrectly or again making contact with the manikin after the competitor has grasped the manikin.
 - (vi) Manikin handler intentionally entering the water during the event or entering the water and interfering with the performance of another competitor or interfering with the judging of the event
 - (vii) At 25m, not touching the 25m marker line before intentionally touching the manikin
 - (viii) Incorrectly securing the rescue tube around the manikin (i.e., not around body and under both arms and not clipped to an O-ring)
 - (ix) Not securing the rescue tube around the manikin within the 10m pick-up zone, judged at the top of the manikin's head
 - (x) The line of the rescue tube not becoming fully extended before the top of the manikin's head passes the 10m line
 - (xi) Not towing the manikin with the line of the rescue tube fully extended beyond the 10m
 - (xii) Towing the manikin with the face below the surface
 - (xiii) Pushing or carrying, instead of towing, the manikin
 - (xiv) The rescue tube and manikin become separated after the rescue tube has been secured correctly around the manikin
 - (xv) Touching the finish wall/edge without the rescue tube and manikin in place
 - (xvi) Failure to touch the finish wall/edge

2.4.7 50m Tube Clip and Swim with Fins

This modified event is held over 50m but the competitor will not tow a manikin. They shall start the event with the rescue tube in the normal starting position and shall swim a distance of 25m to touch a marker line before clipping the tube and towing the rescue tube, returning to the starting point.

This is an U11 event only.

- (a) With a dive start the competitor swims 25m freestyle wearing fins, touches the halfway rope, and clips up the rescue tube at the O-ring before turning back towards the direction in which they swam to touch the finish wall of the pool.

- (b) Competitors must touch the rope prior to the clip-up.
- (c) Handlers – For all events where the manikin is positioned at the 25m mark the same handling rules apply as for a 100m Manikin Tow but with the following conditions. Before the start of the race, the manikin handler positions themselves in the water and behind the 25m marker line. The hands of the handler must be above the water when holding the manikin at the 25m marker line.
- (d) Equipment
 - Manikins: The manikin is filled to halfway with water so that it floats with the top of its transverse line at the surface. Competitors must use the manikins supplied by organisers.
 - Rescue tube: Competitors must use the rescue tubes supplied by organisers.
 - Fins: Swim fins must comply with the specifications in Section 2.3.1 and 2.3.2
- (e) Starts with rescue tubes:
 - At the start, the rescue tube and rescue tube line may be positioned at the competitor's discretion, but within the competitor's allotted lane. Competitors should ensure a safe and correct position of rescue tube and line. The rescue tube remains unclipped until secured around the manikin.
- (f) Wearing rescue tubes:
 - Rescue tubes must be donned correctly, either with the loop over one or two shoulders, or over the shoulder and across the chest – at the competitor's discretion.
 - Assuming the rescue tube was donned correctly, there is no cause for disqualification if the loop falls down on the competitor's arm or elbow during the competitor's approach to the manikin or during the manikin tow.
- (g) Clipping up:
 - After first touching the 25m marker line, the competitor then clips up the rescue tube at the O-ring, within the 10m clip-up zone.
 - Competitors may go back into the 10m change over zone to re-secure the manikin provided the manikin's head has not passed the 10m line.
- (h) Retrieving lost fins:
 - Competitors may retrieve fins lost after the start and continue without disqualification as long as the rules governing manikins are not violated (see Section 3 – Manikins).
 - Competitors are not permitted to start again in another heat.
- (i) Rescue Tube Defect:
 - If in the opinion of the Chief Referee the rescue tube, line and/or harness (belt) presents a technical defect during the race, the Chief Referee may allow the competitor to start again in another heat but only if the rescue tubes for the event were supplied by the organising body and the rules required that the provided tubes must be used by all competitors.
- (j) Disqualification

In addition to the *General Rules* the following behaviour shall result in disqualification:

 - (i) Taking assistance from any pool fitting (e.g., lane rope, steps, underwater hockey fittings) when performing the clip-up except where the minimum pool depth allows the competitor to stand while performing the clip-up
 - (ii) Competitor clipping the rescue tube into the ring before touching the 25m marker line
 - (iii) At 25m, not touching the 25m marker line before intentionally touching the manikin
 - (iv) Incorrectly securing the rescue tube around the manikin (i.e., not around body and under both arms and not clipped to an O-ring)
 - (v) Not performing the clip up within the 10m clip-up zone
 - (vi) The line of the rescue tube not becoming fully extended before the tube passes the 10m line
 - (vii) Failure to touch the finish wall/edge

2.4.8 4 x 50m Modified Medley Relay

Competitors will swim 4 x 50m legs. In the final lap the number 4 swimmer does not tow the number 3 swimmer to the finish. This means the final swimmer swims back towing the rescue tube only.

This is an U11/U12 event only.

- (a) The first competitor: With a dive start on an acoustic signal, the first competitor swims 50m freestyle without fins. The first competitor must break the surface of the water before touching the turning wall/edge.

Note: "Breaking the surface" when swimming means that the competitor's head must break the plane of the surface of the water.
- (b) The second competitor: With a dive start after the first competitor touches the turning wall/edge, the second competitor swims 50m freestyle with fins. The second competitor does not need to surface before touching the turning wall/edge.

- (c) The third competitor: With a dive start after the second competitor touches the turning wall/edge, the third competitor swims 50m freestyle without fins towing a rescue tube. The third competitor touches the turning wall/edge.
- (d) The fourth competitor: The fourth competitor (with fins) is in the water with at least one hand in contact with turning wall/edge or starting block, dons the harness. The fourth competitor may touch or grasp the rescue tube, its harness or line with one hand, before the third competitor has touched the turning wall/edge but must have at least one hand on the turning wall/edge or starting block until the third competitor touches the edge. The fourth competitor may push off the wall/edge with hand, arm, or feet.
- (e) The fourth competitor tows the rescue tube only to the finish
- (f) The event is complete when the fourth competitor touches the finish wall/edge of the pool
- (g) The first and second competitors must leave the water upon finishing their legs of the relay without obstructing any other competitors. The first and second competitors may not re-enter the water.
- (h) Equipment
 - Rescue tube: Competitors must use the rescue tubes supplied by organisers.
 - Fins: Swim fins must comply with the specifications in Section 2.3.1 and 2.3.2
- (i) Starts with rescue tubes:
 - For the third competitor's start, the rescue tube and rescue tube line may be positioned at the competitor's discretion, but within the competitor's allotted lane. Competitors should ensure a safe and correct position of rescue tube and line. The rescue tube remains unclipped throughout.
- (j) Wearing rescue tubes:
 - Rescue tubes must be donned correctly, either with the loop over one or two shoulders, or over the shoulder and across the chest – at the competitor's discretion. Assuming the rescue tube was donned correctly, there is no cause for disqualification if the loop falls down on the competitor's arm or elbow during the competitor's approach or tow.
- (k) Towing the victim:
 - Swimmer 4 does not need to tow swimmer 3 (the victim) in this modified event.
- (l) Retrieving lost fins:
 - Competitors may retrieve fins lost after the start and continue without disqualification as long as the rules governing manikins (if being used in the leg of the race) are not violated (see Section 3 – *Manikins*).
 - Competitors are not permitted to start again in another heat.
- (m) Rescue Tube Defect:
 - If in the opinion of the Chief Referee the rescue tube, line and/or harness (belt) presents a technical defect during the race, the Chief Referee may allow the competitor to start again in another heat but only if the rescue tubes for the event were supplied by the organising body and the rules required that the provided tubes must be used by all competitors.
- (n) Disqualification

In addition to the *General Rules* the following behaviour shall result in disqualification:

 - (i) Leaving the start before the previous competitor has touched the wall/edge
 - (ii) The fourth competitor touching the rescue tube harness, line, or any part of the rescue tube before the third competitor touches the turn wall/edge
 - (iii) The competitor clipping the rescue tube into the ring
 - (iv) One competitor completing two or more legs of the event
 - (v) Failure to touch the finish wall/edge
 - (vi) A competitor re-entering the water after completing his or her leg of the relay

3. MANIKINS

3.1 COMPETITORS SURFACING THE MANIKIN

- (a) Competitors may push off the pool bottom when surfacing with the manikin.
- (b) Competitors must:
 - i. Break the surface of the water while holding the manikin with at least hand and/or arm before the top of the manikin's head passes the designated 5m line (Manikin Carry, Rescue Medley, Super Lifesaver) or 10m line (Manikin Carry with Fins).

Note: "Break the surface" while holding the manikin means that the competitor's head must break the plane of the surface of the water.

- ii. Have the manikin in a correct carrying position when the top of the manikin's head passes the designated 5/10m line.
- iii. Remain at the surface beyond the designated 5/10m line.
- iv. Maintain contact with the manikin at all times beyond the designated 5/10m line until touching the finish wall/edge or the turning wall/edge (as appropriate).

Note 1: "Surface" means the horizontal plane of the surface of a still water pool.

Note 2: The manikin judging criteria applies only when the top of the manikin's head passes the relevant 5/10m line.

3.2 CARRYING THE MANIKIN

- (c) In events where the manikin is carried, the manikin (as victim) is presumed to be non-breathing. Water over the face is not a judged criterion.
- (d) Competitors must carry the manikin with at least one hand and/or arm and must always be in contact with the manikin.
- (e) When carrying the manikin, the competitor's head must be forward of the top of the manikin's head.
- (f) Competitors must carry the manikin with the head of the manikin facing the direction of the carry i.e., the manikin cannot be carried with the bottom of the manikin facing the direction of the carry.
- (g) It is permitted for the manikin to be gripped or grasped by the throat (neck), mouth, nose, eyes or carried with an arm over or around the manikin's throat (neck). It is also permitted for the face of the manikin to be held against the body of the competitor.
- (h) The manikin must not be gripped by the sealing plugs.
- (i) The competitor and manikin are considered to be one unit and, when in the carry position, either must remain above the surface of the water.

Note 1: "Surface" means the horizontal plane of the surface of a still water pool.

Note 2: If the competitor and manikin are both fully "below the surface", when carrying it is a disqualification. However, there is no disqualification if the manikin is underwater and a competitor dips below the surface of the water as part of their normal stroke or kick cycle provided that the competitor breaks the surface throughout the race with some part of their body such as their head or arm.

Note 3: If the competitor and manikin are both below surface as the result of the competitor's final stroke/lunge to touch the turning or finish wall/edge or for a relay exchange, it shall not be a disqualification provided that the lunge to the wall/edge is within the 5m pick up line (as judged when the top of the manikin's head passes within the 5m line). However, when carrying a manikin, the competitor must maintain contact with the manikin with at least one hand and/or arm at all times beyond the designated 5m line until touching the finish wall/edge or the turning wall/edge (as appropriate).

- (j) Carrying the manikin judging criteria applies only when the top of the manikin's head passes the 5m or 10m line.
- (k) In the 5m start zone and in the changeover zones of the Manikin Relay, and the changeover zone of the Lifesaver Relay event, competitors are not judged on carrying the manikin criteria. However, competitors must maintain contact with at least one hand and/or arm with the manikin at all times including during the manikin exchanges.

Note: As with all events, the standard "carrying the manikin" criteria (defined in this section) apply to the final relay competitor at the finish of the Manikin Relay and Lifesaver Relay. That is; the final relay competitor must maintain a correct carry position beyond the designated change over zone until touching the finish wall/edge.

3.3 TOWING THE MANIKIN

- (a) In events where the manikin is towed, the manikin (as victim) is presumed to be breathing. Before the tow, competitors must secure the manikin correctly within the 10m change-over zone. "Correctly" means the rescue tube is secured around the body and under both arms of the manikin and clipped to an O-ring.

Note: It is not a disqualification where the minimum pool depth allows the competitor to stand/walk within the 10m change-over or clip-up zone while securing the rescue tube around the manikin (or victim in the Rescue Tow Relay) provided the top of the manikin's head (or victim) has not passed the 10m line. Competitors may not stand/walk after the manikin's head has passed the 10m line.
- (b) Competitors may return back into the 10m change over zone to re-secure the manikin provided the top of the manikin's head has not passed the 10m line.
- (c) Competitors may swim on their back, side or front and may use any kick or stroke while towing the manikin.
- (d) Beyond the 10m pick-up zone, competitors must tow the manikin correctly secured with the manikin face above the surface of the water.
- (e) Competitors shall be disqualified if the rescue tube and manikin become separated. Competitors shall not be disqualified if the rescue tube slips from under one arm of the Manikin during the tow, provided that the rescue tube was "secured correctly" at the 10m line and the face of the manikin remains above the water surface.

- (f) Competitors shall not be disqualified if the manikin rotates in the rescue tube as long as the manikin's face remains above the surface of the water. In addition, the manikin does not need to be carried headfirst provided it was secured correctly at the 10m line and the manikin's face remains above the surface of the water.
- (g) Provided that the manikin is secured as defined, and the line/rope of the rescue tube has not been intentionally shortened by the competitor/team prior to the commencement of a race for the purpose of towing the manikin (e.g. looping and tying/knotting or clipping the line/rope) the line/rope does not need to be fully extended during tow.
- Note:** Competitors shall not be disqualified if the line of the rescue tube becomes wrapped around the Manikin or is otherwise shortened by a competitor during the conduct of a race.

3.4 MANIKIN HANDLERS

- (a) A member of the competitor's team assists as manikin handler in the Manikin Tow with Fins, the Super Lifesaver, and the Manikin Lifesaver Medley events. A registered team coach, manager or other team personnel are permitted to function as a handler. With the Chief Referee's approval, non-team members may also function as handlers, provided they are registered in the competition in some capacity.
- (b) A manikin handler is not required to wear a competition cap.
- (c) A manikin handler:
- Should understand their role as their actions could result in the disqualification of their competitor.
 - Must comply with all race instructions given by officials.
 - Should hold the manikin with at least one hand.
 - Should make every effort to ensure that any part of their person, the manikin they are holding and/or any water movement they cause does not impede or interfere with any other competitor in the race.
 - May not push the manikin toward the competitor or the finish wall.
 - May be required to enter the water to hold the manikin effectively during modified events.
- (d) For **tow** events the handler;
- May not intentionally enter the water during the event.
 - Holds the manikin upright anywhere within the allotted lane.
 - Ensures the face of the manikin is facing towards the turning edge/wall at the time the competitor touches the turning wall.
 - Ensures that the manikin is floating upright at its natural buoyancy position with the top of its transverse line at the surface.
 - May let go of the manikin after the competitor has touched the turning wall.
 - Must release contact with the manikin immediately once the competitor has deliberately made contact with the manikin to secure it for the tow.
 - If required to enter the water for a modified tow event they must hold the manikin with their hands above the surface of the water.
- (e) For **modified carry** events:
- The handler holds the manikin horizontal on the surface of the water in the middle of the competitor's allotted lane.
 - The handler's hands may be located under the manikin so that it balances on their hands.
 - The face of the manikin must be facing upwards and towards the direction that the competitor will be carrying the manikin.
 - The manikin handler is to release contact with the manikin once the competitor has deliberately made contact with the manikin.
 - The handler may not provide any assistance with the forward movement of the manikin.

4. EVENT DESCRIPTIONS

4.1 OBSTACLE SWIM (200m and 100m)

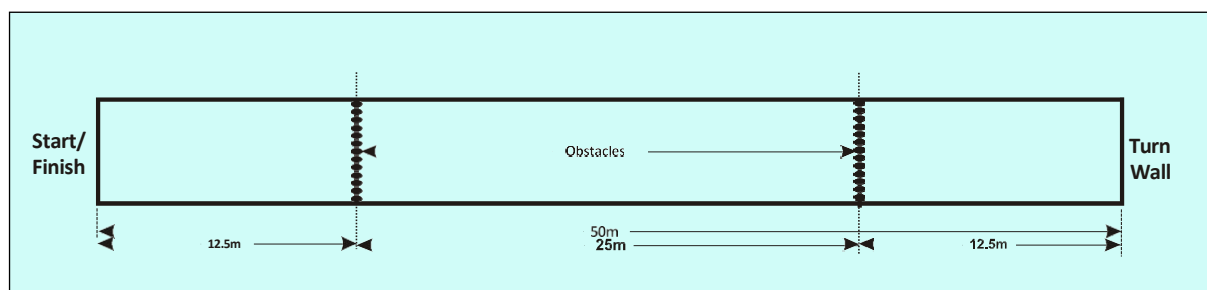

FIGURE 1: OBSTACLE SWIM (200m AND 100m)

4.1.1 Event description – 200m

With a dive start on an acoustic signal, the competitor swims the 200m course passing eight times under the immersed obstacles to touch the finish wall/edge of the pool.

- Competitors must surface after the dive entry before the first obstacle; after passing under each obstacle; and after a turn prior to passing under an obstacle.
- Competitors may push off the pool bottom when surfacing from under each of the obstacles. "Surfacing" means the competitor's head breaks the plane of the surface of the water.
- Swimming into or otherwise bumping an obstacle is not a behaviour that results in disqualification.

4.1.2 Event description – 100m

With a dive start on an acoustic signal, the competitor swims the 100m course passing four times under the immersed obstacles to touch the finish wall/edge of the pool.

- Competitors must surface after the dive entry before the first obstacle; after passing under each obstacle; and after a turn prior to passing under an obstacle.
- Competitors may push off the pool bottom when surfacing from under each of the obstacles.
- "Surfacing" means the competitor's head breaks the plane of the surface of the water.
- Swimming into or otherwise bumping an obstacle is not a behaviour that results in disqualification.

4.1.3 Equipment

- Obstacles:** See ILS Competition Rule Book Section 8 for specifications
Obstacles are fixed at right angles onto lane ropes in a straight line across all lanes. The first obstacle is located 12.5m from the start wall, with the second obstacle located 12.5m from the opposite end. The distance between the two obstacles is 25m.

4.1.4 Disqualification

In addition to the *General Rules* the following behavior shall result in disqualification:

- Passing over an obstacle without immediately returning over or under that obstacle and then passing under it (DQ11).
- Failure to surface after the dive entry or after a turn before and after passing under an obstacle. (DQ12).
- Taking assistance from any pool fitting (e.g., lane rope, steps, drains or underwater hockey fittings) when surfacing – not including the bottom of the pool (DQ17).
- Failure to touch the wall/edge during the turn (DQ13).
- Failure to touch the finish wall/edge (DQ14).

4.2 MANIKIN CARRY (50m)

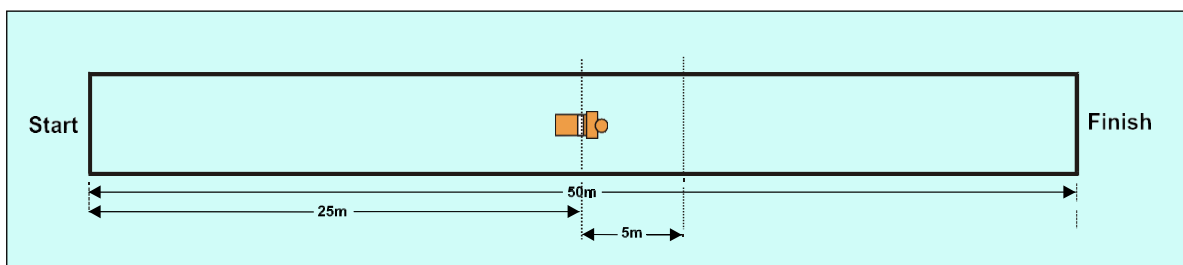

FIGURE 2: MANIKIN CARRY (50M)

4.2.1 Event description

- (a) Competitors must break the surface of the water after the dive entry and before diving to recover the manikin.
Note: “Break the surface of the water” when means that the competitor’s head must break the plane of the surface of the water.
- (b) The competitor surfaces the manikin within the 5m pick-up zone and carries it with at least one hand and/or arm to the finish wall/edge of the pool.
Note: “Surfacing with the Manikin means that the competitor’s head must break the plane of the surface of the water while holding the manikin with at least one hand or arm before the top of the manikin’s head passes the designated 5m line.
- (c) Competitors may push off the pool bottom when surfacing with the manikin.
- (d) The event is complete when the competitor touches the finish wall/edge of the pool.

4.2.2 Equipment

- (a) **Manikin:** See ILS Competition Rule Book Section 8 for specifications
The manikin is completely filled with water and sealed for the event. Competitors must use the manikins supplied by organisers.
Positioning the manikin: The manikin is located at a depth between 1.8 m and 3 m. In water deeper than 3m, the manikin shall be placed on a platform (or other support) to position it at the required depth. The manikin is positioned on its back, the head in the direction of the finish, with the top of the transverse line on the 25m line.
Surfacing the manikin: Competitors must have the manikin in the correct carrying position before the top of the manikin’s head passes the 5m line.

4.2.3 Disqualification

In addition to the General Rules the following behavior shall result in disqualification:

- (a) Not surfacing before diving to the manikin (DQ15).
- (b) Taking assistance from any pool fitting (e.g., lane rope, steps, drains or underwater hockey fittings) when surfacing with the manikin – not including the bottom of the pool (DQ17).
- (c) Not having the manikin in the correct carrying position before the top of the manikin’s head passes the 5m line (DQ18).
- (d) Using an incorrect carrying technique as described in S3-3 Manikins (DQ19).
- (e) Releasing the manikin before touching the finish wall/edge (DQ21).
- (f) Failure to touch the finish wall/edge (DQ14).

4.3 RESCUE MEDLEY (100m)

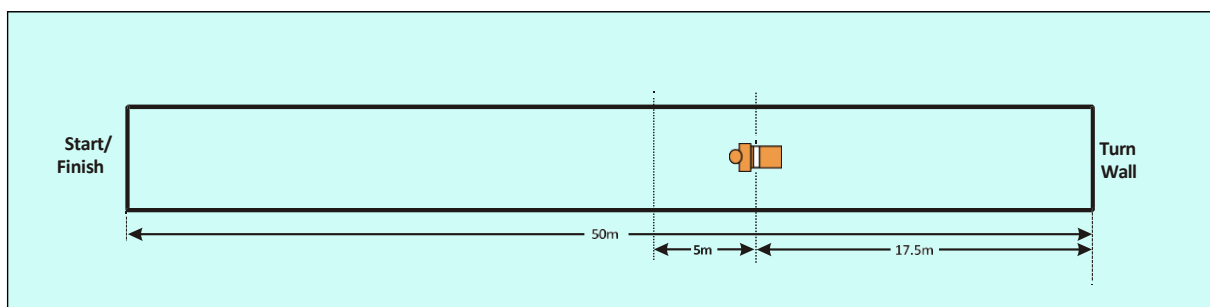

FIGURE 3: RESCUE MEDLEY (100M)

4.3.1 Event description

- With a dive start on an acoustic signal, the competitor swims 50m freestyle to turn, dive, and swim underwater to a submerged manikin located at 17.5m from the turning wall.
- Competitors must break the surface of the water after the dive entry and before touching the 50m turning wall/edge and before turning and diving to recover the manikin.
Note: “Break the surface” when swimming means that the competitor’s head must break the plane of the surface of the water.
- The competitor surfaces the manikin within the 5m pick-up line and then carries it with at least one hand and/or arm the remaining distance to touch the finish wall/edge.
Note: “Surfacing with the Manikin means that the competitor’s head must break the plane of the surface of the water while holding the manikin with at least one hand or arm before the top of the manikin’s head passes the designated 5m line.
- Competitors are permitted to take a breath, or breaths before, at, or during the turn, but must not take a breath after their feet and/or hands leave the turning wall/edge to swim underwater to the manikin and until they surface with the manikin.
- Competitors may push off the bottom when surfacing with the manikin but not during the underwater swim to the manikin.

4.3.2 Equipment

- Manikin:** See ILS Competition Rulebook Section 8 for specifications
The manikin is completely filled with water and sealed for the event. Competitors must use the manikins supplied by organisers.
Positioning the manikin: The manikin is located at a depth between 1.8m and 3m. In water deeper than 3m, the manikin shall be placed on a platform (or other suitable support) to position it at the required depth. The manikin is positioned on its back, head in the direction of the finish, with the top of the transverse line on the 17.5m line.
Surfacing the manikin: Competitors must have the manikin in the correct carrying position before the top of the manikin’s head passes the 5m line.

4.3.3 Disqualification

In addition to the *General Rules* the following behavior shall result in disqualification:

- Competitor not surfacing after the dive entry and before touching the 50m turning wall/edge. (DQ16).
- Surfacing after turning and before lifting the manikin (DQ22).
- Taking assistance from any pool fitting (e.g., lane rope, steps, drains or underwater hockey fittings) when surfacing with the manikin – not including the bottom of the pool (DQ17).
- Not having the manikin in the correct carrying position before the top of the manikin’s head passes the 5m line (DQ18).
- Using an incorrect carrying technique as described in S3-3 Manikins (DQ19).
- Releasing the manikin before touching the finish wall/edge (DQ21).
- Failure to touch the finish wall/edge (DQ15).

4.4 MODIFIED RESCUE MEDLEY (50m)

RLSSA Modifications (taken from 2026 RLSSA Sport and Competition Handbook)

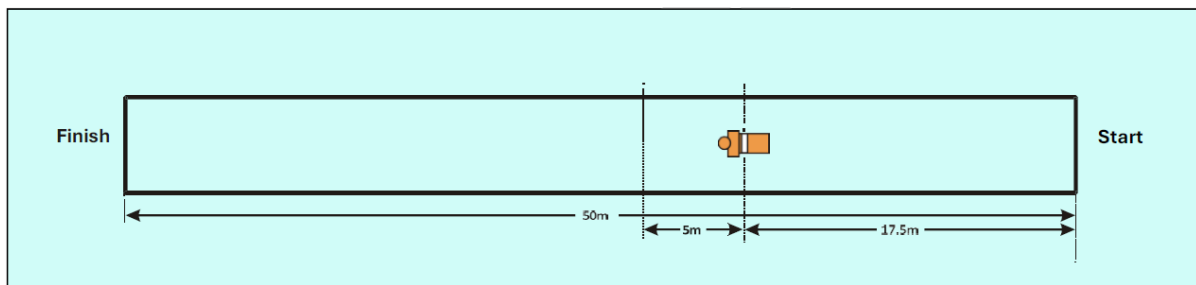

FIGURE 4: MODIFIED RESCUE MEDLEY (50M)

4.4.1 Event description

- With a dive start on an acoustic signal, the competitor swims freestyle underwater to a submerged manikin located at 17.5m from the start wall.
- The competitor must not break the surface of the water after the dive entry until they have recovered the manikin.
- They must swim underwater without a breath from the turn until they surface with the manikin.
- Competitors may not push off the bottom during the underwater approach to the manikin but may push off the bottom to surface the manikin.
- The competitor surfaces the manikin within the 5m pick-up zone and then correctly carries it the remaining distance to touch the finish wall.

4.4.2 Equipment

- Manikin:** See ILS Competition Rulebook Section 8 for specifications
The manikin is completely filled with water and sealed for the event. Competitors must use the manikins supplied by organisers.

Positioning the manikin: The manikin is located at a depth between 1.8m and 3m. In water deeper than 3m, the manikin shall be placed on a platform (or other suitable support) to position it at the required depth. The manikin is positioned on its back with the transverse line in the middle of the manikin's thorax located on the 17.5m line.

Surfacing the manikin: Competitors must have the manikin in the correct carrying position before the top of the manikin's head passes the 5m pick-up zone.

4.4.3 Disqualification

In addition to the *General Rules* the following behavior shall result in disqualification:

- Surfacing after the start and before surfacing the manikin.
- Taking assistance from any pool fitting (e.g., lane rope, steps, drains or underwater hockey fittings) when surfacing with the manikin – not including the bottom of the pool (DQ17).
- Not having the manikin in the correct carrying position before the top of the manikin's head passes the 5m line (DQ18).
- Using an incorrect carrying technique as described in S3-3 Manikins (DQ19).
- Releasing the manikin before touching the finish wall/edge (DQ21).
- Failure to touch the finish wall/edge (DQ15).

4.5 MANIKIN CARRY WITH FINS (100m)

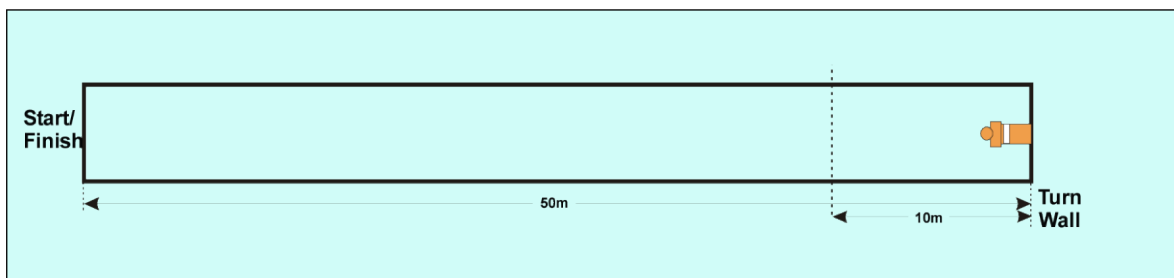

FIGURE 5: MANIKIN CARRY WITH FINS (100m)

4.5.1 Event description

- (a) With a dive start on an acoustic signal, the competitor swims 50m freestyle wearing fins and then recovers a submerged manikin. The competitor surfaces the manikin within the 10m pick-up line and then carries it with at least one hand and/or arm the remaining distance to touch the finish wall/edge.

Note: Surfacing with the Manikin means that the competitor's head must break the plane of the surface of the water while holding the manikin with at least one hand or arm before the top of the manikin's head passes the designated 10m line.

- (b) Competitors need not surface before touching the manikin.
(c) Competitors do need not touch the turning wall/edge of the pool.
(d) Competitors may push off the bottom when surfacing with the manikin.

4.5.2 Equipment

- (a) **Manikin, fins:** See ILS Competition Rulebook Section 8 for specifications
The manikin is completely filled with water and sealed for the event. Competitors must use the manikins supplied by organisers.

Positioning the manikin: The manikin is located at a depth between 1.8m and 3m. In water deeper than 3m, the manikin shall be placed on a platform (or other suitable support) to position it at the required depth. The manikin is positioned on its back in contact with the pool bottom and its base touching the pool wall, with its head in the direction of the finish.

Where the facility design does not provide a vertical wall that joins the bottom at 90 degrees, the manikin must be positioned as close as possible to the wall, but no further than 300mm from the wall as measured at the water surface.

Surfacing the manikin: Competitors must have the manikin in the correct carrying position before the top of the manikin's head passes the 10m line.

- (b) **Retrieving lost fins:** Competitors may retrieve fins lost after the start and continue without disqualification as long as the rules governing manikins are not violated (see Section 3 – *Manikins*). Competitors are not permitted to start again in another heat.

4.5.3 Disqualification

In addition to the *General Rules* the following behaviour shall result in disqualification:

- (a) Taking assistance from any pool fitting (e.g., lane rope, steps, drains or underwater hockey fittings) when surfacing with the manikin – not including the bottom of the pool (DQ17).
(b) Not having the manikin in the correct carrying position before the top of the manikin's head passes the 10m line (DQ23).
(c) Using an incorrect carrying technique as described in S3-3 Manikins (DQ19).
(d) Releasing the manikin before touching the finish wall/edge (DQ21).
(e) Failure to touch the finish wall/edge (DQ14).

4.6 MANIKIN TOW WITH FINS (100m)

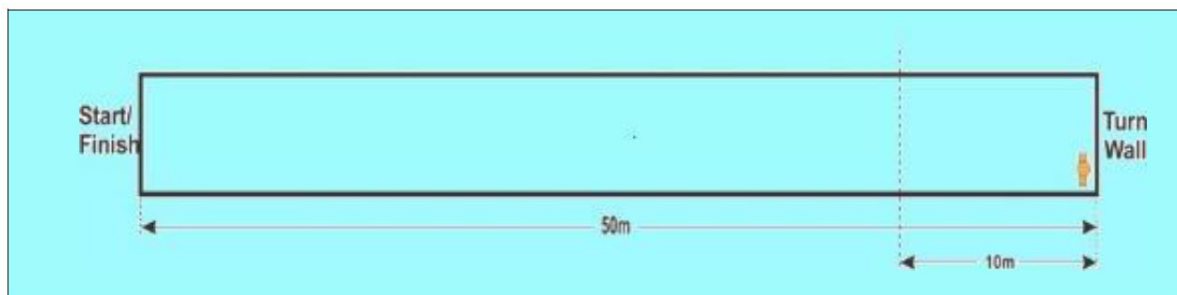

FIGURE 6: MANIKIN TOW WITH FINS (100m)

4.6.1 Event description

- With a dive start on an acoustic signal, the competitor swims 50m freestyle with fins and rescue tube.
- After touching the turn wall/edge, and within the 10m pick-up zone, the competitor fixes the rescue tube correctly around a manikin and tows it to the finish. Competitors must have the manikin in the correct carrying position before the top of the manikin's head passes the 10m line.
- The event is complete when the competitor touches the finish wall/edge of the pool.
- Competitors need not surface before touching the turning wall/edge.

4.6.2 Equipment

- Manikin, fins, rescue tube:** See ILS Competition Rulebook Section 8 for specifications
The manikin is filled with water so that it floats with the top of its transverse line at the surface. Competitors must use the manikins and rescue tubes supplied by organisers.
- Positioning the manikin:** For the handover, a manikin handler, using at least one hand, holds the manikin upright anywhere within the allotted lane with the face of the manikin facing toward the turning edge/wall at the time the competitor touches the turning wall/edge. Manikin handlers may not intentionally enter the water during the event.
- Starts with rescue tubes:** At the start, the rescue tube and rescue tube line may be positioned at the competitor's discretion, but within the competitor's allotted lane. Competitors should ensure a safe and correct position of rescue tube and line. The rescue tube remains unclipped in the rescue tube and rescue tube line until secured around the manikin.

Note: Although the rescue tube and rescue tube line may be positioned at the competitor's discretion for the start (including the line/rope being wrapped around their body, tucked into swimsuits, etc.), competitors shall be disqualified if the rescue tube tow line/rope is tied/knotted or clipped within itself to intentionally shorten the line/rope prior to the commencement of a race.

- Wearing rescue tubes:** Rescue tubes must be donned correctly, either with the lanyard/harness over one or both shoulders, or over one shoulder and across the chest – at the competitor's discretion. Assuming the rescue tube was donned correctly, there is no cause for disqualification if the lanyard/harness falls down on the competitor's arm or elbow or is re positioned during the competitor's approach to the manikin or during the manikin tow.
- Securing the manikin:** After first touching the turning wall/edge, the competitor then secures the manikin correctly with the rescue tube around the body and under both arms of the manikin, and clipped to an O-ring, within the 10m change-over zone. Competitors may go back into the 10m change over zone to re-secure the manikin. provided the top of the manikin's head has not passed the 10m line.

Note 1: Unintentionally touching the manikin before touching the turning wall/edge is not a disqualification.

Note 2: Standing or walking while clipping the rescue tube around the manikin is not a disqualification provided that the top of the manikin's head remains within the 10m changeover zone.

- Towing the manikin:** Competitors must tow the manikin as detailed in the general conditions for pool competition. The rescue tube must be attached to the manikin by the time the top of the manikin's head passes the 10m line.

Note 1: Refer to starts with rescue tubes - Competitors shall be disqualified if the tow line/rope of the rescue tube is intentionally shortened by a competitor prior to the commencement of a race for the purpose of towing the manikin (e.g. looping and tying/knotting or clipping the line/rope).

Note 2: Competitors shall not be disqualified if the line of the rescue tube becomes wrapped around the Manikin or is otherwise shortened by a competitor during the conduct of a race.

- Competitors shall be disqualified if the rescue tube and manikin become separated. Competitors shall not be disqualified if the rescue tube slips from under one arm of the Manikin during the tow, provided that the rescue tube was "secured correctly" at the 10m line and the face of the manikin remains above the water surface.

- (h) Competitors shall not be disqualified if the manikin rotates in the rescue tube as long as the manikin's face remains above the surface of the water. The manikin does not need to be carried headfirst provided it was secured correctly at the 10m line and the manikin's face remains above the surface of the water.
- (i) **Retrieving lost fins:** Competitors may retrieve fins lost after the start and continue without disqualification as long as the rules governing manikins are not violated (see S3-3 Manikins). Competitors are not permitted to start again in another heat.
- (j) **Rescue Tube Defect:** If in the opinion of the Chief Referee the rescue tube, line and/or harness (belt) presents a technical defect during the race, the Chief Referee may allow the competitor to start again in another heat but only if the rescue tubes for the event were supplied by the organising body and the rules required that the provided tubes must be used by all competitors.

4.6.3 Disqualification

In addition to the *General Rules* the following behaviour shall result in disqualification:

- (a) Taking assistance from any pool fitting (e.g., lane rope, steps, underwater hockey fittings) when fixing the rescue tube around the manikin except where the minimum pool depth allows the competitor to stand while securing the rescue tube around the manikin. (DQ24).
- (b) Competitor clipping the rescue tube into the ring before touching the turning wall/edge. (DQ28)
- (c) Manikin handler releasing the manikin before the competitor touches the turning wall/edge (DQ26).
- (d) Manikin handler intentionally entering the water during the event or entering the water and interfering with the performance of another competitor or interfering with the judging of the event (DQ27).
- (e) At 50m, the competitor not touching the pool wall/edge before intentionally touching the manikin (DQ25).
- (f) Incorrectly securing the rescue tube around the manikin (i.e., not around body and under both arms and not clipped to an O-ring) (DQ29).
- (g) Not securing the rescue tube around the manikin within the 10m change-over zone, judged at the top of the manikin's head (DQ30).
- (h) The line/rope of the rescue tube being intentionally shortened by a competitor prior to the commencement of a race for the purpose of towing the manikin (DQ32).
- (i) Towing the manikin with the face below the surface (DQ20).
- (j) Pushing or carrying, instead of towing, the manikin (DQ31).
- (k) The rescue tube and manikin become separated after the rescue tube has been secured correctly around the manikin (DQ33).
- (l) Touching the finish wall/edge without the rescue tube and manikin in place (DQ34).
- (m) Failure to touch the finish wall/edge (DQ14).

4.7 SUPER LIFESAVER (200m)

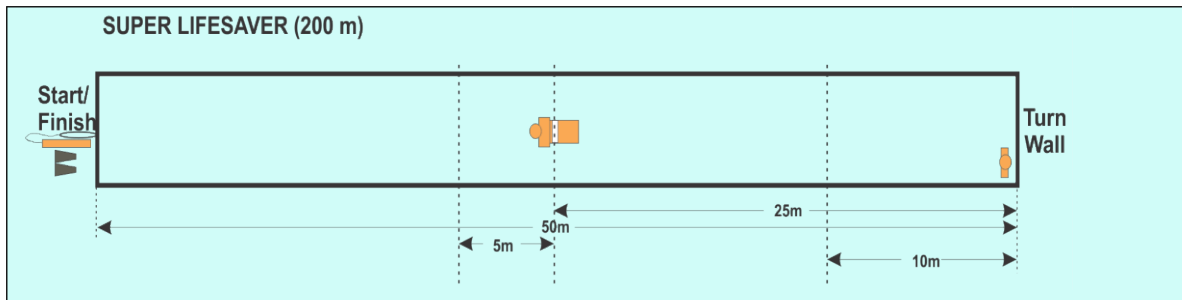

FIGURE 7: SUPER LIFESAVER (200m)

4.7.1 Event description

- With a dive start on an acoustic signal, the competitor swims 75m freestyle and then dives to recover a submerged manikin.
- Competitors must break the surface of the water after the dive entry and before touching the 50m turning wall/edge.
Note: "Breaking the surface" when swimming means that the competitor's head must break the plane of the surface of the water.
- The competitor surfaces the manikin within the 5m pick-up line and then carries it with at least one hand and/or arm the remaining distance to touch the turning wall/edge. After touching the wall/edge, the competitor releases the manikin.
Note: Surfacing with the Manikin means that the competitor's head must break the plane of the surface of the water while holding the manikin with at least one hand or arm before the top of the manikin's head passes the designated 10m line.
- In the water, the competitor puts on fins and rescue tube and swims 50m freestyle. After touching the wall/edge, and within the 10m change-over zone, the competitor fixes the rescue tube correctly around a manikin and tows it to the finish.
- The event is complete when the competitor touches the finish wall/edge of the pool.

4.7.2 Equipment

- Manikin, fins, rescue tube:** See ILS Competition Rulebook Section 8 for specifications
The first manikin that is used for the carry is completely filled with water and sealed for the event. The second manikin that is used for the tow is filled with water and sealed so that it floats with the top of its transverse line at the surface.
- Placement of fins and rescue tubes:** Prior to the start, competitors must place the fins and rescue tube on the pool deck – not the starting block/podium – within the confines of their allotted lane. The rescue tube remains unclipped until secured around the manikin.
Note: Although the rescue tube and rescue tube line may be positioned at the competitor's discretion, competitors shall be disqualified if the rescue tube tow line/rope is tied/knotted or clipped within itself to intentionally shorten the line/rope prior to the commencement of a race.
- Positioning the manikin for the carry:** The manikin is located at a depth between 1.8m and 3m. In water deeper than 3m, the manikin shall be placed on a platform (or other support) to position it at the required depth. The manikin is positioned on its back, head in the direction of the finish with the top of the transverse line on the 25m line.
- Surfacing the first manikin:** Competitors may push off the bottom of the pool when surfacing with the manikin. Competitors must have the manikin in the correct carrying position before the top of the manikin's head passes the 5m line.
- Donning tube and fins:** After first touching the turning wall/edge, the competitor discards the first manikin. In the water, the competitor don's fins and rescue tube and swims 50m freestyle.
Note: It is permitted to maintain contact with the turning wall/edge while donning the rescue tube and/or fins.
- Wearing rescue tubes:** Rescue tubes must be donned correctly, either with the lanyard/harness over one or both shoulders, or over one shoulder and across the chest – at the competitor's discretion.
Note: Assuming the rescue tube was donned correctly, there is no cause for disqualification if the lanyard/harness falls down on the competitor's arm or elbow or is re positioned during the competitor's approach to the manikin or during the manikin tow.

- (g) **Positioning the manikin:** For the handover, a manikin handler, using at least one hand, holds the manikin upright anywhere within the allotted lane with the face of the manikin facing toward the turning edge/wall at the time the competitor touches the turning wall/edge. Manikin handlers may not intentionally enter the water during the event.
- (h) **Securing the manikin:** After first touching the turning wall/edge, the competitor then secures the manikin correctly with the rescue tube around the body and under both arms of the manikin, and clipped to an O-ring, within the 10m change-over zone. Competitors may go back into the 10m change over zone to re-secure the manikin provided the top of the manikin's head has not passed the 10m line.
 Note 1: Unintentionally touching the manikin before touching the turning wall/edge is not a disqualification.
 Note 2: Standing or walking while clipping the rescue tube around the manikin is not a disqualification provided that the top of the manikin's head remains within the 10m changeover zone.
- (i) **Towing the manikin:** Competitors must tow the manikin as detailed in the general conditions for pool competition. The rescue tube must be attached to the manikin by the time the top of the manikin's head passes the 10m line.
 Note 1: Refer to placement of fins and rescue tubes - Competitors shall be disqualified if the tow line/rope of the rescue tube is intentionally shortened by a competitor prior to the commencement of a race for the purpose of towing the manikin (e.g. looping and tying/knotting or clipping the line/rope).
 Note 2: Competitors shall not be disqualified if the line of the rescue tube becomes wrapped around the Manikin or is otherwise shortened by a competitor during the conduct of a race.
- (j) Competitors shall be disqualified if the rescue tube and manikin become separated. Competitors shall not be disqualified if the rescue tube slips during the tow, provided that the rescue tube was "secured correctly" at the 10m line and that the face of the manikin remains above the water surface.
- (k) Competitors shall not be disqualified if the manikin rotates in the rescue tube as long as the manikin's face remains above the surface of the water. The manikin does not need to be carried headfirst provided it was secured correctly at the 10m line and the manikin's face remains above the surface of the water.
- (l) **Retrieving lost fins:** Competitors may retrieve fins lost after the start and continue without disqualification as long as the rules governing manikins are not violated (see S3-3 Manikins). Competitors are not permitted to start again in another heat.
- (m) **Rescue Tube Defect:** If in the opinion of the Chief Referee the rescue tube, line and/or harness (belt) presents a technical defect during the race, the Chief Referee may allow the competitor to start again in another heat but only if the rescue tubes for the event were supplied by the organising body and the rules required that the provided tubes must be used by all competitors.

4.7.3 Disqualification

In addition to the *General Rules* the following behaviour shall result in disqualification:

- (a) Competitor not surfacing after the dive entry and before touching the 50m turning wall/edge. (DQ16).
- (b) Taking assistance from any pool fitting (e.g., lane rope, steps, drains or underwater hockey fittings) – not including the bottom of the pool when surfacing the manikin (DQ17).
- (c) Not having the manikin in the correct carrying position before the top of the manikin's head passes the 5m pick-up zone (DQ18).
- (d) Using an incorrect carrying technique as described in S3-3 Manikins. (DQ19).
- (e) Releasing the manikin before touching the turning wall/edge. (DQ21).
- (f) Taking assistance from any pool fitting (e.g., lane rope, steps, underwater hockey fittings) when fixing the rescue tube around the manikin except where the minimum pool depth allows the competitor to stand/walk while securing the rescue tube around the manikin provided the top of the manikin's head has not passed the 10m line. (DQ24).
- (g) Competitor clipping the rescue tube into the ring before touching the turning wall/edge. (DQ28).
- (h) Manikin handler releasing the manikin before the competitor touches the turning wall/edge (DQ26).
- (i) Manikin handler intentionally entering the water during the event or entering the water and interfering with the performance of another competitor or interfering with the judging of the event (DQ27).
- (j) At 150m, the competitor not touching the pool wall/edge before intentionally touching the second manikin (DQ25).
- (k) Incorrect securing of the rescue tube around the manikin (i.e., not around body and under both arms and not clipped to an O-ring) (DQ29).
- (l) Not securing the rescue tube around the manikin within the 10m change-over zone judged at the top of the manikin's head (DQ30).
- (m) The line/rope of the rescue tube being intentionally shortened by a competitor prior to the commencement of

- a race, or by a handler, for the purpose of towing the manikin (DQ32).
- (n) Towing the manikin with the face below the surface (DQ20).
 - (o) Pushing or carrying, instead of towing, the manikin (DQ31).
 - (p) The rescue tube and manikin become separated after the rescue tube has been secured correctly around the manikin (DQ33).
 - (q) Touching the finish wall/edge without the rescue tube and manikin in place (DQ34).
 - (r) Failure to touch the finish wall/edge (DQ14).

4.8 LINE THROW

RLSSA Modifications (taken from 2026 RLSSA Sport and Competition Handbook)

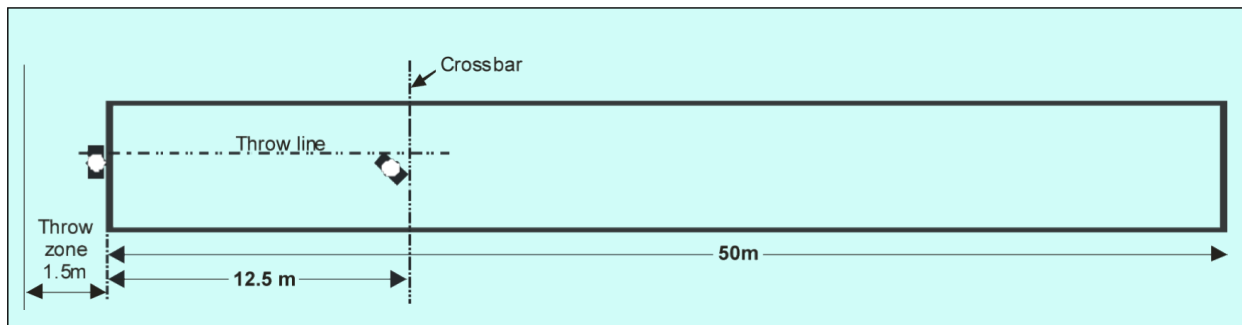

FIGURE 8: Line Throw

4.8.1 Event description

- In this timed event (45 seconds), the competitor throws an unweighted rope to an endorsed competitor (participant) of the same gender located in the water on the near side of a rigid crossbar/line located 12.5 m distant.
- At the start signal the thrower shall retrieve the rope, throw it back to the victim. If it is a fair throw the victim grasps the rope and then the competitor pulls the “victim” back to the finish wall of the pool.
- Note the follow distances for each age group
 - U14- Masters throw distance is 12.5m
 - U13-U14 throw distance is 10m
 - U11-U12 throw distance is 8m
- Victims may wear swim goggles. As this is an individual event the victim must be an endorsed competition participant.

Throw Zone

- The Throw zone is the area bounded by each competitor’s allocated lane. It extends from the vertical edge of the pool wall to the front of a competitor’s lane and is defined by the sides by an unmarked extended line in the middle of the lane ropes on each side of the competitor’s lane and to the edge of the pool deck or raised platform.
- The back line of the throw zone is 2m beyond the vertical edge of the pool wall to allow for an unimpeded throw and haul in. The back line of the throw zone is to be marked as a reference point for competitors and officials.
- Dependent on pool design, the 2m back line may extend from the pool edge beyond the width of a raised pool edge or bulkhead/pontoon i.e. any bulkhead/pontoon forms part of the 2m from the pool edge.

Time Limit

- Within 45 seconds competitors must make a fair throw and pull the victim to the finish wall.
- If a throw falls short or outside the allocated lane, competitors may recover the rope and throw again as often as necessary within the 45-second limit.
- Competitors who fail to get their victim to the finish wall before the 45 second shall be designated as “Did Not Finish” (DNF).

The Start

- Preparing for the start:** No practice throws are permitted prior to the start. When three short whistles are blown both the thrower and victim step into their allocated throw area and take possession of their rope.
- On the first whistle:** The “thrower” (competitor) holds one end of the throw rope in one hand. The “victim” takes the other end of the rope, enters the water and proceeds to the 12.5m crossbar. The rope is extended between the “thrower” and “victim”. The surplus rope is extended beyond the crossbar, either over or under the crossbar.
- At the second whistle:** competitors and victims take up their positions for the start without undue delay. When all competitors have assumed their starting positions, the starter shall give the command “Take your mark”.
- Starting position:** The thrower is free to adopt any position within their throw zone for the start. The end of the throw rope must be held in one hand, but it is not permitted to wrap the rope around this hand.

The victim is located on the near side of the rigid crossbar in the allotted lane. The victim grasps the crossbar/line with one hand or two hands. The victim is not required to be in contact with the throw rope at the start of the event.

- (e) **Acoustic starting signal:** When all throwers and victims are stationary the Starter give the acoustic starting signal and the thrower shall retrieve the rope. The victim may release their contact with the cross bar after the starting signal to re-adjust their position without penalty.

Fair Throw

- (a) A fair throw is one where a victim is able to grasp the thrown rope with their hand but only within their designated lane either in front or behind the crossbar. A thrown rope lying over the lane rope is not "within the lane".

Grasping the Rope

- (a) The victim may only grasp the rope if it a fair throw.
- (b) The victim may not release the crossbar/line until they are grasping the throw rope with their other hand.
- (c) The victim can slide their hand anywhere along the cross bar but must be grasping the crossbar with one hand when using any part of their body to attempt to gather or grasp the thrown rope with their other hand or when touching the rope with any part of their body.
- (d) Victims may submerge to retrieve the throw rope.
- (e) As long as victims remain entirely within their designated lane and they do not release their hold of the crossbar, they may use their foot or another part of their body to manoeuvre the throw rope within their lane to a position where they can grasp the rope with their hand.
- (f) There is no penalty for pulling the crossbar while attempting to reach the throw rope.

Pull Through the Water

- (a) Pull through the water must cover the following actions:
- **Victims:** While being pulled to the edge, victims must be on their front grasping the throw rope with both hands. Victims may not "climb" the throw rope hand-over-hand. For safety reasons, victims may release the rope with one hand for the sole purpose of touching the wall. This will not result in disqualification.
After touching the finish wall the victim may not exit the water.
Note: "Climbing" the rope is defined as the victim using their hands to move up the rope towards the end held by the thrower.
 - **Thrower:** The thrower must pull their victim into the finish wall using their arms. While pulling their victim in a backward movement within the 2m backline is permitted. They are not permitted to:
 - walk or run with the rope only grasped in their hands or
 - hold the rope around any part of their body or
 - to move backwards beyond the 2m backline while pulling their victim into the finish wall
 - Throwers must remain in their throw zone until their victim touches the finish wall, or the event is signalled as complete (whichever occurs first).

Throw Zone Conditions

- (a) A Thrower must not interfere with other competitors or use the space allocated to the adjoining lane. This is demonstrated by the thrower remaining within their throw zone.
- (b) Competitors who exit the throw zone while pulling their victim into the edge shall be disqualified. Similarly, the competitor should remain in the throw zone until the official acoustic completion signal.
- (c) For the purposes of judging, throwers are still required to remain within their lane. However, the focus is not on the placement of feet but, rather on them not interfering with another competitor.
- (d) A thrower remaining within their throw zone; This is defined as the thrower maintaining at least one foot wholly within the inside edge of their throw zone or marked 2m backline, either on the ground or in the air above their throw zone.
- (e) Any part of the thrower's feet may cross over the front of the 'pool edge' in their throw zone.
- (f) Throwers may reach to retrieve a rope dropped outside the throw zone as long as there is no interference with another competitor or an official.
- (g) Throwers who enter or fall into the water shall be disqualified.
- (h) Any backward movement within the 2m backline is not a disqualification provided that the thrower remains within their throw zone until the victim touches the finish wall.

Event Conclusion and Dismissal

- (a) At the conclusion of the event there are 2 different signals given, the first (1st) to indicate that the 45 second time limit has elapsed and the second (2nd) to indicate the conclusion of the race and that participants are dismissed from the competition area.
- (b) **End of time limit:** This is an acoustic signal which may be either the same as the start signal, a long whistle or a water polo timing mechanism siren. This indicates the end of event race component, but throwers and victims are expected to stay within their throw zones.
- (c) Within the time limit the following applies. After touching the finish wall the victim may not exit the water and should remain in their allocated lane. The competitor will be disqualified if their victim attempts to climb out of the water past their waist or sits on the pool edge before the official acoustic completion signal is given.

4.8.2 Equipment

- (a) **Throw line:** See ILS Competition Rule Book Section 8 for specifications.
The line used for the line throw events shall be plaited, buoyant polypropylene with nonmemory characteristics with a diameter of 8mm and length minimum 16.5m and maximum 17.5m. Competitors must use the throw lines supplied by organisers.
- (b) **Rigid Cross Bar:** Minimum pool depth of 1.8m extending at least 2.0m from the rigid crossbar, along the course towards the start point. The rigid crossbar is positioned at the surface across each lane at 12.5 m from the start end of the pool. The throw zone on pool deck extends from the pool wall back 2.0m.

4.8.3 Disqualification

In addition to the *General Rules* the following behaviour shall result in disqualification:

- (a) Competitor executing practice throw(s) (DQ52).
- (b) Victim not keeping a grasp on the crossbar with their hand when using any part of their body to gather or to grasp the line/rope for the pull to the finish wall/edge. (DQ45).
- (c) Victim grasping the throw line/rope outside the designated lane (DQ48).
- (d) Victim not on their front while being pulled to the finish wall/edge (DQ49).
- (e) Victim not holding the throw line/rope with both hands while being pulled to the finish wall/edge (victim may release the line/rope with one hand for the sole purpose of touching the wall/edge) (DQ50).
- (f) Victim "climbing" the throw line/rope hand-over-hand (DQ51).
- (g) Competitor who, after the start signal and before their victim touches the finish wall//edge, exits their allocated throw zone (DQ46).
- (h) Competitor not hauling in using their arms and walking or running with the line/rope grasped in their hands or held around any part of their body or hauling in beyond the 2m back line mark to return the victim to the pool finish wall/edge. (DQ47).
- (i) Failure to touch the finish wall/edge (DQ14).

Note: Failure to get the victim to the finish wall before the 45-second completion signal shall be designated "Did Not Finish" (DNF).

4.9 MANIKIN RELAY (4 x 25m)

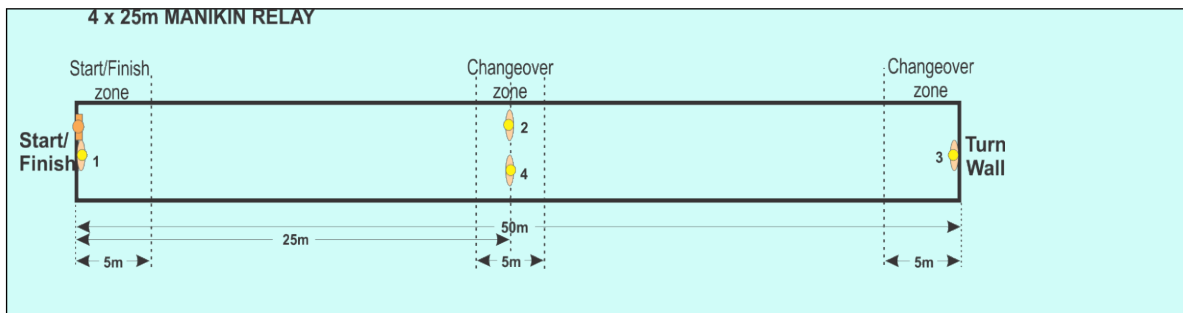

FIGURE 9: MANIKIN RELAY (4 X 25M)

4.9.1 Event description

Four competitors in turn carry a manikin approximately 25m each.

- On the first long whistle, all competitors enter the water. On the second long whistle, all competitors, without undue delay, prepare for the start.
- The first competitor is holding a manikin with one hand and/or arm and the start wall/edge or starting block with the other hand and the second, third, and fourth competitors are in the water at the 25m, 50m, and 75m marks, respectively.
- When all competitors have assumed their starting positions, the Starter shall give the command "Take your Marks."
- When the first competitors are stationary, the Starter gives the acoustic starting signal.
- The first competitor:** The first competitor carries the manikin with at least one hand and/or arm and passes it to the second competitor within the 5m changeover zone situated between the 22.5m and 27.5m mark.
- The second competitor:** The second competitor carries the manikin with at least one hand and/or arm to touch the turning wall/edge and passes the manikin to the third competitor who is in contact with the turning wall/edge or starting block with at least one hand.
- The third competitor:** The third competitor may touch or grasp the manikin with one hand before the second competitor touches the turning wall/edge or starting block but must not release contact with the turning wall/edge or starting block until the second competitor has touched the turning wall/edge.
The third competitor carries the manikin with at least one hand and/or arm and passes it to the fourth competitor in the changeover zone between the 72.5m and 77.5m mark.
- The fourth competitor:** The fourth competitor completes the event by carrying the manikin with at least one hand and/or arm to touch the finish wall/edge with any part of the competitor's body.
- Only the incoming and outgoing competitors may participate in the manikin exchange within their changeover zones. The incoming competitors may assist outgoing competitors, but only as long as the top of the manikin's head remains within the changeover zones.
- The hand and/or arm of one competitor must be in contact with the manikin at all times.
- The start zone and relay changeover zones shall be indicated by flags, poles, or cones.
- Competitors involved in the exchange may push off the pool bottom in the changeover zone.
- In the start and in changeover zones competitors are not judged on "carrying the manikin" criteria (defined in Section 3 - Manikins) however competitors need to maintain contact with the manikin with at least one hand and/or arm at all times and including during the exchanges.
Note: The standard "carrying the manikin" criteria (defined in Section 3 - *Manikins*) apply to the final relay competitor at the finish of the event.
- The manikin exchange must take place within the designated changeover zones, as judged by the top of the manikin's head.
- Once they have completed their individual leg of the race and the exchange the first and third competitors should remain in the water, in their lane in the changeover zone, staying clear of the final manikin exchanges. The first and third competitors may leave the water after all the fourth competitors have the manikin and are clear of the 5m changeover zone or a team has withdrawn from an event. Competitors should leave the water by crossing to the nearest side of the pool and without obstructing any other competitors.
- The second competitors may leave the water after all the third competitors have the manikin and are clear of the 5m changeover zone or a team has withdrawn from an event. All competitors should leave the water by crossing to the nearest side of the pool and without obstructing any other competitors. The first, second and third

competitors may not re-enter the water.

(q) The fourth competitors must not leave the water before the all clear signal is given.

4.9.2 Equipment

- (a) **Manikin:** See ILS Competition Rulebook Section 8 for specifications
The manikin is completely filled with water and sealed. Competitors must use the manikins supplied by organisers.

4.9.3 Disqualification

In addition to the *General Rules* the following behaviour shall result in disqualification

- (a) Using incorrect manikin carry technique as described in Section 3 – *Manikins* (DQ19).
- (b) Taking assistance from any pool fitting (e.g., lane rope, steps, drains or underwater hockey fittings) – not including the bottom of the pool (DQ17).
- (c) The third competitor releasing contact with the turning wall/edge/starting block before the second competitor has touched the wall/edge (DQ37).
- (d) The manikin changing hands before or beyond the designated changeover zone (DQ38).
- (e) Assistance from a third competitor during the exchange between the incoming and outgoing competitors (DQ35).
- (f) Releasing the manikin before the next competitor has grasped it (i.e., one hand and/or arm of each competitor must be in contact with the manikin) (DQ39).
- (g) Not having the manikin in the correct carrying position before the top of the manikin's head passes the 5m line (DQ18).
- (h) Releasing the manikin before touching the turning wall/edge or finish wall/edge (DQ21).
- (i) Failure to touch the finish wall/edge (DQ14).
- (j) A competitor re-entering the water after completing their leg of the relay (DQ44).
- (k) One competitor completing two or more legs of the event (DQ36).

4.10 OBSTACLE RELAY (4 x 50m)

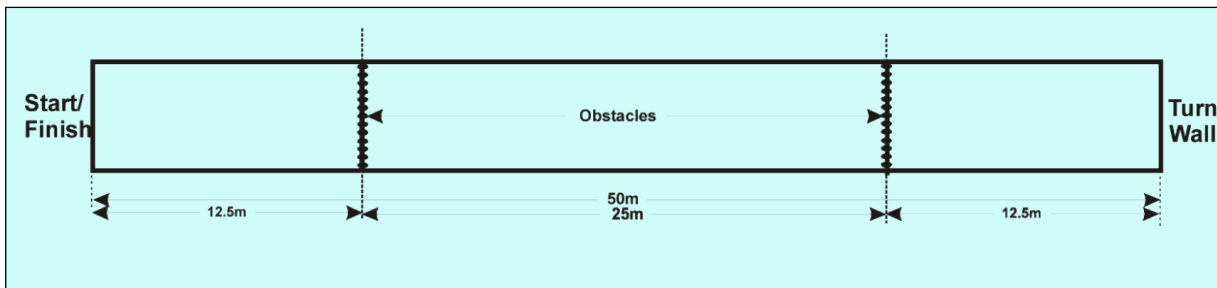

FIGURE 10: OBSTACLE RELAY (4 X 50m)

4.10.1 Event description

Four competitors in turn swim a distance of 50m under obstacles.

- The first competitor:** With a dive start on an acoustic signal, the first competitor swims 50m freestyle passing under two obstacles.
- The second, third and fourth competitors:** After the first competitor touches the turning wall/edge the second, third, and fourth competitors repeat the procedure in turn.
- All competitors must surface after the dive entry before the first obstacle and after passing under each obstacle. "Surfacing" means the competitor's head breaks the surface of the water.
Note: "Breaking the surface" when swimming means that the competitor's head must break the plane of the surface of the water.
- Competitors may push off the pool bottom when surfacing from under the obstacles.
- Swimming into or otherwise bumping an obstacle is not a behaviour that results in disqualification.
- The first, second and third competitors must leave the water upon finishing their legs of the relay without obstructing any other competitors. The first, second and third competitors may not re-enter the water.

4.10.2 Equipment

- Obstacles:** See ILS Competition Rule Book Section 8 for specifications
Obstacles are fixed at right angles onto lane ropes in a straight line across all lanes. The first obstacle is located 12.5m from the start wall, with the second obstacle located 12.5m from the opposite end. The distance between the two obstacles is 25m.

4.10.3 Disqualification

In addition to the *General Rules* the following behaviour shall result in disqualification:

- Passing over an obstacle and not immediately returning over or under that obstacle and then passing under it (DQ11).
- Failure to surface after the dive entry or before and after passing under an obstacle. (DQ12).
- Taking assistance from any pool fitting (e.g., lane rope, steps, drains or underwater hockey fittings) when surfacing – not including the bottom of the pool (DQ17).
- Leaving the starting block before the previous competitor has touched the wall/edge (DQ37).
- Failure to touch the finish wall/edge (DQ14).
- A competitor re-entering the water after completing their leg of the relay (DQ44).
- One competitor repeating two or more legs of the event (DQ36).

4.11 MEDLEY RELAY (4 x 50m)

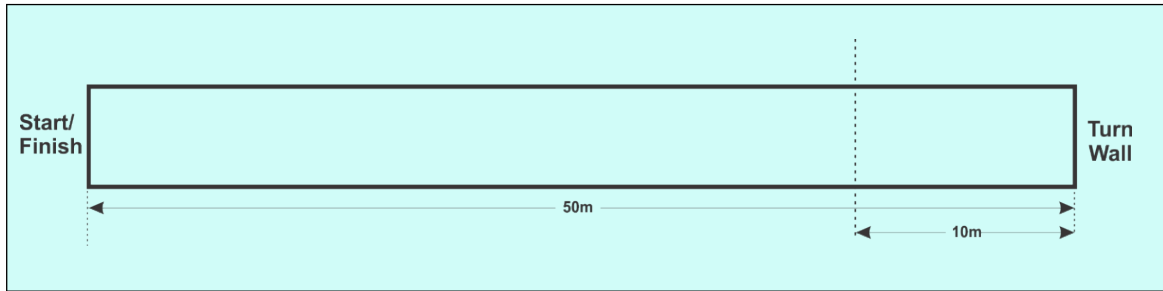

FIGURE 11: MEDLEY RELAY (4 X 50m)

4.11.1 Event description

Four competitors in turn swim a distance of 50m undertaking different tasks.

- (a) **The first competitor:** With a dive start on an acoustic signal, the first competitor swims 50m freestyle without fins. The first competitor must break the surface of the water before touching the turning wall/edge. Note: "Breaking the surface" when swimming means that the competitor's head must break the plane of the surface of the water.
- (b) **The second competitor:** With a dive start after the first competitor touches the turning wall/edge, the second competitor swims 50m freestyle with fins. The second competitor does not need to surface before touching the turning wall/edge.
- (c) **The third competitor:** With a dive start after the second competitor touches the turning wall/edge, the third competitor swims 50m freestyle without fins towing a rescue tube. The third competitor touches the turning wall/edge.

Note: Although the rescue tube and rescue tube line may be positioned at the competitor's discretion for the changeover (including the line/rope being wrapped around their body, tucked into swimsuits, etc.), teams shall be disqualified if the rescue tube tow line/rope is tied/knotted or clipped within itself to intentionally shorten the line/rope prior to the commencement of a race.

- (d) **The fourth competitor:** The fourth competitor (with fins) is in the water with at least one hand in contact with turning wall/edge or starting block, dons the harness. The fourth competitor may touch or grasp the rescue tube, its harness or line with one hand, before the third competitor has touched the turning wall/edge but must have at least one hand on the turning wall/edge or starting block until the third competitor touches the edge. The fourth competitor may push off the wall/edge with hand, arm, or feet.
- (e) The third competitor, playing the role of "victim," holds the rescue tube and/or clip with both hands while being towed 50m by the fourth competitor to the finish.
- (f) The victim must have the correct hold with the rescue tube when the top of the "victim's" head crosses the 10m line.

Note 1: The third and fourth competitors are permitted to stand/walk after touching the turning edge and before the victim's head has passed the 10m line with the victim in contact with the rescue tube.

Note 2: Refer to the third competitor changeover - Teams shall be disqualified if the tow line/rope of the rescue tube is intentionally shortened prior to the commencement of the third competitor's leg of the race for the purpose of towing the victim (e.g. looping and tying/knotting or clipping the line/rope).

Note 3: Competitors shall not be disqualified if the line of the rescue tube becomes wrapped around the victim or is otherwise shortened by a competitor during the conduct of a race.

- (g) The victim may kick while being towed, but no other assistance is permitted.
- (h) The victim must grip the main body of the rescue tube and/or clip – not the rope.
- (i) The victim must hold onto the rescue tube and/or clip with both hands while being towed but may reposition their hands on the tube and/or clip during the tow without disqualification.
- (j) The event is complete when the fourth competitor touches the finish wall/edge of the pool with the victim in contact with the rescue tube.
- (k) The first and second competitors must leave the water upon finishing their legs of the relay without obstructing any other competitors. The first and second competitors may not re-enter the water

4.11.2 Equipment

- (a) **Rescue tube, swim fins:** See ILS Competition Rule Book Section 8 for specifications. Competitors must use the rescue tubes supplied by organisers.
- (b) **Starts with rescue tubes:** For the third competitor's start, the rescue tube and rescue tube line may be positioned at the competitor's discretion, but within the competitor's allotted lane. Competitors should ensure a safe and correct position of rescue tube and line. The rescue tube remains unclipped throughout.
- (c) **Wearing rescue tubes:** Rescue tubes must be donned correctly, either with the lanyard/harness over one or both shoulders, or over one shoulder and across the chest – at the competitor's discretion. Assuming the rescue tube was donned correctly, there is no cause for disqualification if the lanyard/harness falls down on the competitor's arm or elbow or is re positioned during the competitor's approach or tow.
- (d) **Towing the victim:** Victims must be holding the rescue tube and/or clip correctly at the time the top of the victim's head passes the 10m line.
- (e) **Retrieving lost fins:** Competitors may retrieve fins lost after the start and continue without disqualification as long as the rules governing manikins (if being used in the leg of the race) are not violated (see 3.3 Manikins). Competitors are not permitted to start again in another heat.
- (f) **Rescue Tube Defect:** If in the opinion of the Chief Referee the rescue tube, line and/or harness (belt) presents a technical defect during the race, the Chief Referee may allow the competitor to start again in another heat but only if the rescue tubes for the event were supplied by the organising body and the rules required that the provided tubes must be used by all competitors.

4.11.3 Disqualification

In addition to the *General Rules* the following behaviour shall result in disqualification:

- (a) First competitor not surfacing after the dive entry and before touching the turning wall/edge. (DQ16).
- (b) Leaving the starting block/releasing contact with the turning wall/edge/starting block before the previous competitor has touched the wall/edge (DQ37).
- (c) The competitor clipping the rescue tube into the O-ring (DQ40).
- (d) The victim holding the rescue tube by the rope (DQ41).
- (e) The victim helping with arm movements or not holding the rescue tube and/or clip with both hands (DQ42).
- (f) The victim not holding or losing the rescue tube (or clip) after passing the 10m line (DQ43).
- (g) One competitor completing two or more legs of the event (excludes third competitor acting as victim) (DQ36).
- (h) Failure to touch the finish wall/edge (DQ14).
- (i) A competitor re-entering the water after completing their leg of the relay (DQ44).

4.12 FIN RELAY – MIXED (8 x 50m)

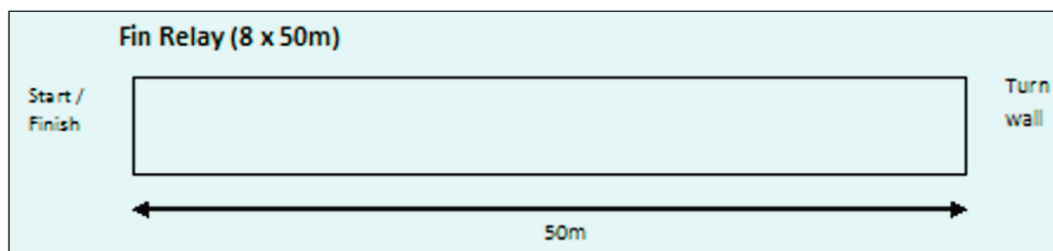

FIGURE 12: FIN RELAY (8 X 50m)

4.12.1 Event description

- 4 males and 4 females drawn from any age group within the registered team. Competitors need only hold the award appropriate for their nominated age division.
- With a dive start on an acoustic signal, the first competitor swims 50m freestyle with fins. After the first competitor touches the turn wall, the second through to eighth competitors repeat the procedure in turn.
- Competitors may perform the majority of the lap underwater but must take one full arm stroke above the water on completion of the lap.
- Modifications to the Rules for NSW Branch are as follows:
 - Any age group
 - 4 x 50m Freestyle with Fins Relay swum in accordance with 8 x 50m Fin Relay.
 - Individual 50m or 25m Fin swim sprint conducted under the same conditions as a lap swimmer in the 8 x 50m Fin Relay

4.12.2 Equipment

- Swim fins:** See Section 2.3.1 and Section 2.3.2 for swim fin specifications.

4.12.3 Disqualification

In addition to the *General Rules* the following behaviour shall result in disqualification:

- Failure to complete the lap with one full arm stroke.
- One competitor repeating two or more legs of the event.
- Teams/competitor not swimming in their designated lane.
- Failure to touch the finish wall.
- A competitor re-entering the water after completing his or her leg of the relay.
- Leaving the start before the previous competitor has touched the wall.

4.13 DISQUALIFICATION CODES FOR POOL EVENTS

Code and Disqualification	Events
1. Not completing the event in accordance with the event description or general rules.	All events
2. A competitor or team may be disqualified if a competitor, team, or handler is deemed to have competed unfairly. Examples of “competing unfairly” include: <ul style="list-style-type: none"> • Committing a doping or doping-related infraction. • Impersonating another competitor. • Attempting to defeat the ballot or draw for events or positions. • Competing twice in the same individual event. • Competing twice in the same event in different teams. • Purposely interfering with a course to gain advantage. • Jostling or obstructing another competitor or handler so as to impede their progress. • Receiving physical or material outside assistance (other than verbal or other direction). • Participating contrary to the spirit of the competition (as described in the code of fair play). 	All events
3. Competitors may not be permitted to start in an event if they are late reporting to the marshalling area. This may be noted as a “did not start” (DNS) or similar on result sheets.	All events
4. A competitor or team absent from the start of an event shall be disqualified except for the A- or B-final. This may be noted as a “did not start” (DNS) or similar on result sheets.	All events
5. Activities that result in willful damage to the venue sites, accommodation sites or the property of others will result in disqualification of the individuals involved from competition.	All events
6. Abuse of officials resulting in disqualification from the competition.	All events
7. Using sticky, tacky, or adhesive substances (liquid, solid or aerosol) on hands or feet, or on the manikin or rescue tube to improve grip or push of the bottom of the pool.	All events
8. Taking assistance from the pool bottom except where specifically allowed (i.e. Obstacle Swim and Relay, 4 x 25m Manikin Relay, Manikin Tow, Super Lifesaver, Medley Relay).	All events
9. Leaving the water after an event before permission is given by the official.	All events
10. Initiating a starting motion before the starting signal has been given	All events
11. Passing over an obstacle without immediately returning over or under that obstacle and then passing under it.	Obstacle Swim, Obstacle Relay
12. Failure to surface after the dive entry or after a turn before passing under an obstacle.	Obstacle Swim, Obstacle Relay
13. Failure to touch the wall/edge during the turn.	Obstacle Swim
14. Failure to touch the finish wall/edge.	All events
15. Not surfacing before diving to the manikin.	Manikin Carry
16. Competitor not surfacing after the dive entry and before touching the 50m turning wall/edge	Rescue Medley, Superlifesaver
17. Taking assistance from any pool fitting (e.g., lane rope, steps, drains or underwater hockey fittings) when surfacing with the manikin (as applicable for the event) – not including, where specified, the bottom of the pool.	Manikin Carry, Rescue Medley, Manikin Carry with Fins, Superlifesaver, Manikin Relay, Obstacle Relay

18. Not having the manikin in a correct carrying position before the top of the manikin's head passes the 5m line (for carries without fins).	Manikin Carry, Manikin Relay Rescue Medley, Superlifesaver
19. Using an incorrect carrying technique (as described in 3.3 Manikins).	Manikin Carry, Manikin Carry with Fins, Manikin Relay, Rescue Medley, Superlifesaver
20. Towing the manikin with the face below the surface.	Manikin Tow with Fins, Superlifesaver
21. Releasing the manikin before touching the finish wall/edge or the turn wall/edge.	Manikin Carry, Manikin Carry with Fins, Rescue Medley, Superlifesaver, Manikin Relay,
22. Surfacing after turning and before lifting the manikin.	Rescue Medley
23. Not having the manikin in the correct carrying position before the top of the manikin's head passes the 10m line (for carries with fins).	Manikin Carry with Fins
24. Taking assistance from any pool fitting (e.g., lane rope, steps, underwater hockey fittings) when fixing the rescue tube around the manikin (or victim in the Rescue Tow Relay) except where the minimum pool depth allows the competitor to stand/walk while securing a rescue tube around the manikin (or victim) (i.e. Manikin Tow, Super Lifesaver, Manikin Lifesaver Medley, Rescue Tow Relay).	All events
25. At 50m / 150m, competitor not touching the pool wall/edge before intentionally touching manikin.	Manikin Tow with Fins, Superlifesaver
26. Manikin handler releasing the manikin before the competitor touches the turning wall/edge).	Manikin Tow with Fins, Superlifesaver
27. Manikin handler intentionally entering the water during the event or entering the water and interfering with the performance of another competitor or interfering with the judging of the event.	Manikin Tow with Fins, Superlifesaver
28. Competitor clipping the rescue tube into the O-ring before touching the turning wall/edge.	Manikin Tow with Fins, Superlifesaver
29. Incorrect securing of the rescue tube around the manikin (i.e., not around body and under both arms and not clipped to an O-ring).	Manikin Tow with Fins, Superlifesaver
30. Not securing the rescue tube around the manikin within the 10m pick-up zone (judged at the top of the manikin's head).	Manikin Tow with Fins, Superlifesaver
31. Pushing or carrying, instead of towing the manikin.	Manikin Tow with Fins, Superlifesaver
32. The line of the rescue tube being intentionally shortened by a competitor prior to the commencement of a race for the purpose of towing the manikin/victim.	Manikin Tow with Fins, Superlifesaver, Medley Relay
33. The manikin/victim becoming detached from the rescue tube (other than a technical defect with the tube – see tube defect note) after passing the 10m line and prior to the rescuer touching the finishing edge/wall.	Manikin Tow with Fins, Superlifesaver
34. Touching the finish wall/edge without the rescue tube and manikin in place.	Manikin Tow with Fins, Superlifesaver
35. Assistance from a third competitor during the exchange between the incoming and outgoing competitors.	Manikin Relay
36. One competitor repeating two or more legs of the event.	Obstacle Relay, Manikin Relay, Medley Relay

37. Leaving the starting block/releasing contact with the turning wall/edge/ starting block before the previous competitor has touched the wall/edge. Note: The second competitor in the Pool Lifesaver Relay is not required to touch the turning wall/edge before or following surfacing with the manikin. However, the third competitor must not release contact with the turning wall/edge until the head of the manikin has broken the surface of the water and they have grasped the manikin.	Obstacle Relay, Manikin Relay, Medley Relay
38. The manikin changing hands before or beyond the designated changeover zone	Manikin Relay
39. Releasing the manikin before the next competitor has grasped it (i.e., one hand of each competitor must be in contact with the manikin).	Manikin Relay, Pool Lifesaver Relay
40. The competitor clipping the rescue tube into the ring.	Medley Relay
41. The victim holding the rescue tube by the rope.	Medley Relay
42. The victim helping with arm movements, or not holding the rescue tube and/or clip with both hands.	Medley Relay
43. The victim not holding or losing the rescue tube after passing the 10m line.	Medley Relay
44. A competitor re-entering the water after completing their leg of the relay.	Obstacle Relay, Manikin Relay, Medley Relay
45. Victim not keeping a grasp on the crossbar with their hand when using any part of their body to gather or to grasp the line for the pull to the finish wall/edge.	Line Throw
46. Line/Rope Thrower who, after the start signal and before their victim touches the finish wall/edge, exits their allocated throw zone.	Line Throw
47. Line/Rope Thrower not hauling in using their arms and walking or running with the line/rope grasped in their hands or held around any part of their body or hauling in beyond the 2.0m back line mark to return the victim to the pool finish wall/edge).	Line Throw
48. Victim grasping the throw line/rope outside their lane.	Line Throw
49. Victim not on their front while being pulled to the finish wall/edge.	Line Throw
50. Victim not holding the throw line with both hands while being pulled to the finish wall/edge (victim may release the line with one hand for the sole purpose of touching the wall/edge).	Line Throw
51. Victim "climbing" the throw line hand-over-hand.	Line Throw
52. Line/Rope thrower executing practice throws.	Line Throw
Note: In the Line Throw event failure to get the victim to the finish wall/edge before the 45-second acoustic completion signal shall be designated DNF, not a DQ	

5. COMPETITION ENTRY

5.1 Registration and Entry

- (a) The Competitor Organiser in consultation with the Organising Committee shall organise any registration that may be required to attend the Competition.
- (b) Registration may be required by all officials, coaches, team management, spectators, and other participants.

5.2 Entry Processing

- (a) For details of the athlete/managers' role in the entry procedure refer to the RLSSA Competition Handbook Section 1 (Rule 1.11 and 1.12).
- (b) The processing of entries and the preparation of the event competition program is the responsibility of the Championship Organiser, and they must be familiar with the entry requirements and procedures. This includes facilitating electronic entry files required for event processing.

5.3 Electronic Entry Procedures and Responsibilities

- (a) The software programs owned and used for entry and recording are Hy-Tec products - '*Team Manager*' and '*Meet Manager*' (MM).
- (b) When the venue for the competition is confirmed, the Championship Organiser must confirm with venue management that the MM software will interface effectively with the venue's AOE system.
- (c) A copy of the Competition MM events file should be supplied to the venue by the Championship Organiser in the week prior to the Day 1 of competition. The Championship Organiser, in consultation with the Chief Recorder, will organise a computer interface check on the day prior to the first event.
- (d) The Championship Organiser must prepare a *Meet Manager* file for the current Competition, called the Competition Program file, and then save a copy of the associated entry file ready for distribution as part of the registration/entry procedure. Team managers should receive the entry file along with '*Team Manager Lite Instructions*' document that provides the exact entry instructions on how to enter competitors and submit files.
- (e) Event entries must be submitted electronically, and any hard copies should be returned with a request for the electronic copy.

The electronic entry processing procedure is:

1. The '*Team Manager Lite*' Entry system must be used by managers to enter their competitors.
 - a. The event entry must nominate which events each competitor is to enter and an entry time where applicable
 - b. Competitors and teams are not required to compete in all events and managers should not enter competitors in events they have no intention of contesting.
 - c. If no entry time is supplied then the competitor will be entered as a "no time" and seeded in the slowest heat.
2. The electronic entry requires that managers will download/import the current Competition Program file (export the details to a .zip file)
3. When a returned electronic entry file is received the Championship Organiser should import it immediately into the MM program.
4. Once an electronic entry has been entered a '*Team Manager*' form should be generated via '*Meet Manager*' and then returned to the relevant managers in a timely manner to check that their entries are correct.
5. As soon as possible after checking the '*Team Manager*' form the Manager must advise the Championship Organiser that either the entries are correct or of any mistakes.
6. Immediately after the closing date for entries the Championship Organiser will seed the Competition event program using the downloaded entry information.
7. After the closing date the following applies
 - a. Event entries received will be considered as late entries and the appropriate penalty fees may apply.
 - b. Late event entries received and/or entry correction are only included in the competition if lane space and administration logistics permits their inclusion or correction.
 - c. All substitutions and withdrawals must follow the procedures

5.4 Recording and Event Preparation

- (a) Prior to the commencement of competition, the Championship Organiser is responsible for ensuring that all events have been organised according to the requirements below. For full details about event preparation and recording procedures refer to Section 1 – *General Rules & Procedures*, however the following are required prior to the start of Competition.
 - 5.4.1.1.1.1 The CO ensures that a complete copy of the speed event heats as well as the SERC and CPR draws are provided to each team at the Coaches’/Manager’s Meeting. NB This information should also be available via the MM app once this meeting is completed
 - 5.4.1.1.1.2 On the day prior to the first day of competition automated/electronic event entry files are imported into the Competition venue’s recording software and becomes the responsibility of the Chief Recorder.
 - 5.4.1.1.1.3 As soon as possible after entries have been received competitor order in events will be determined.
 - 5.4.1.1.1.3.1 Speed events will be seeded and organised according to submitted times. Heats will not be reseeded to accommodate late entries.
- (b) All speed events conducted at the Competition will be timed finals. A timed final is an event where a final is not conducted, and the final result is determined by times swum in the heats. At the direction of the Chief Referee, event/s may be nominated to be run with heats and finals. However, if there are only enough competitors entered for one heat to be swum, then it shall be deemed a final
- (c) Additional to the Championship Organiser collating the athlete entries, they are also required is required to prepare the recording information for Speed events and point score as outlined below.

Championships Point score recording.

- (a) Point scores will be calculated by the Championship Organiser using Meet Manager software in the week following the competition.
- (d) Results will be separated into Royal Life Saving and Surf Life Saving point scores.
- (e) Royal Life Saving point scores will be determined in accordance with the RLSNSW Club & Competition Handbook (Section 9.1 – Pointscore and Appendix M). A summary is provided below:
 - 5.4.1.1.5.1 A pointscore will be conducted on an inter-club basis at all officially sanctioned competitions.
 - 5.4.1.1.5.2 Points will be awarded based on final placings only. For the purpose of this rule, “final” includes all divisions of an event where applicable.
 - 5.4.1.1.5.3 Points will be allocated as follows:
 - 5.4.1.1.5.3.1 1st place receives 3 points.
 - 5.4.1.1.5.3.2 2nd place receives 2 points.
 - 5.4.1.1.5.3.3 3rd place receives 1 point.
 - 5.4.1.1.5.4 For speed events only the highest placed competitor (or team) from each club shall be eligible to receive points
- (f) Surf Life Saving pointscores will be determined in accordance with the SLSA Surf Sports Manual (Section 2.25 – Participants, Medals, Trophies and Pointscores).

Protest Form

(A separate form is to be used for each protest)

TEAM PROTESTING: _____

EVENT UNDER PROTEST: _____ HEAT: _____ LANE: _____

COMPETITOR / TEAM: _____

CLUB: _____

TIME OF INCIDENT UNDER PROTEST: _____

BRIEF DESCRIPTION OF INCIDENT UNDER PROTEST:

REASON FOR PROTEST:

RULES RELATING TO THE INCIDENT AND PROTEST:

IS VIDEO EVIDENCE GOING TO BE PROVIDED? **YES / NO**

NAME AND POSITION OF THE TEAM OFFICIAL SUBMITTING THIS FORM:

SIGNATURE: _____ DATE: _____

OFFICIAL USE ONLY

TIME VERBAL ADVICE GIVEN _____

TIME FORM RECEIVED: _____

IS THE FORM CORRECTLY AUTHORISED **YES/ NO**

HAVE RESULTS BEEN WITHHELD **YES / NO**

REFEREE NAME: _____

PROTEST DECISION: **DISMISSED UPHELD**

EXPLANATION OF DECISION:

PROTEST HAS MERIT: **YES / NO**

TIME COPY GIVEN: TO PROTESTOR: _____

TO SUBJECT OF PROTEST: _____

TO CHAMPIONSHIP CHIEF REFEREE: _____

RESULTS RELEASED (*5 minutes after protest decision released*) **YES / NO**

Appeals Form

(A separate form is to be used for each protest)

TEAM APPEALING: _____

EVENT UNDER APPEAL: _____ HEAT: _____ LANE: _____

COMPETITOR / TEAM: _____

CLUB: _____

TIME OF ADVICE OF PROTEST DECISION RECEIVED APPEAL: _____

REASON FOR APPEAL:

RULES RELATING TO THE INCIDENT AND APPEAL:

IS ADDITIONAL VIDEO EVIDENCE GOING TO BE PROVIDED? **YES / NO**

NAME AND POSITION OF THE TEAM OFFICIAL SUBMITTING THIS FORM:

SIGNATURE: _____ DATE: _____

OFFICIAL USE ONLY

TIME VERBAL ADVICE GIVEN: _____

TIME FORM RECEIVED: _____

WITHIN THE TIME LIMIT **YES / NO**

APPEALS COMMITTEE: (Names of those in attendance)

APPEALS DECISION: **DISMISSED** **UPHELD**

EXPLANATION OF DECISION:

COPY OF APPEAL DECISION PROVIDED: **YES / NO**

APPEAL HAS MERIT: **YES / NO**

SIGNATURE: _____ POSITION: _____

TIME COPY GIVEN: TO PROTESTOR: _____

TO SUBJECT OF PROTEST: _____

TO CHIEF REFEREE: _____

RESULTS RELEASED (*5 minutes after protest decision released*) **YES / NO**

The appeals committee convenor will make copies of results of the appeal available to the teams concerned and the chief referee